

“Mock-up and model of Boeing 737-300 from nose to front door”



BS Aviation Management

By

Bakhtawar Kaleem – S2019001045

Ahtesham Tariq – S2019001029

Muhammad Asad – S2019001020

Safa Imran – S2019001030

Farah Raza – F2018001110

Suman David – S2019001006

Iqra Javed – F20180011155

**Syed Faseeh Ahmed Bukhari –
F2018001036**

Mohammad Sami– S2019001014

Dawood Ahmad Awan – S2019001018

Abdullah Mahmood – S2019001067

Arsla Majeed – F2018001085

Research Advisor

Sir Kalim ur Rehman

Institute of Aviation Studies, IAS

University of Management and Technology Lahore, Pakistan

2023

Approval certificate

It is certified that the contents and form of this final year project, titled as “Design and Development of a “3-D Mockup and Model (Nose and Cockpit Protion) of Boeing 737-300” under the open sky at suitable location within UMT” submitted by the following students have been found satisfactory for the requirement of the degree of BS Aviation Management.

Participants:

Ahtesham Tariq – S2019001029
Bakhtawar Kaleem – S2019001045
Muhammad Asad – S2019001020
Iqra Javed – F20180011155
Arsla Majceed – F2018001085
Abdullah Mahmood – S2019001067
Safa Imran – S2019001030
Farah Raza – F2018001110
Suman David – S2019001006
Syed Faseeh Ahmed Bukhari –F2018001036
Mohammad Sami– S2019001014
Dawood Ahmad Awan – S2019001018

Project Advisor:- Sir Kaleem Ur Rehman



Associate Principal IAS: Dr. Ahmad Aizaz

Principal
Institute of Aviation Studies (IAS)
University of Management and Technology

Principal IAS: Capt. Imran Saeed

University of Management and Technology, Lahore

Similarity Report

Turnitin Originality Report

Mock-Up and Model of Boeing 737-300 from Nose to Front Door by Bakhtawar Kaleem, Iqra Javed, Arsla Majeed, Safa Imran, Farah Raza, Suman David, Ahtesham Tariq, Syed Faseeh Ahmed Bukhari, Mohammad Sami, Dawood Ahmad Awan, Abdullah Mahmood and Muhammad Asad

From Thesis (Reference Section)

- Processed on 03-Feb-2023 09:58 PKT
- ID: 2005327501
- Word Count: 10087

Similarity Index

3%

Similarity by Source

Internet Sources:

2%

Publications:

2%

Student Papers:

1%

Sources:

1. 1% match ()
Caggiano, Alessandra, Marzano, Adelaide, Teti, Roberto. "Resource Efficient Configuration of an Aircraft Assembly Line". 'Elsevier BV', 2016
2. < 1% match (student papers from 29-Sep-2022)
Submitted to Higher Education Commission Pakistan on 2022-09-29



Checked by



For Verified by CLO

Note:

- Sometimes the overall similarity index may be a smaller than the repository percentages combined. This would be due to overlapping text within the repositories.
- It is a system generated report.

Abstract

A mockup of a Boeing 737-300 nose till front door is created for the purpose of students learning regarding various design elements used in the actual construction of the aircraft. The mockup is constructed using materials and manufacturing techniques representative of those used in the actual production of the Boeing 737-300. Original B737-300 is replicated in a scale-down mockup to engage visitors and students to improve the learning of upcoming batches of IAS (Institute of Aviation Studies). A Mockup is created to provide hands-on learning opportunities for students in aviation programs. The Idea of a Boeing 737 mock-up popped into our mind because B737 can best justify the traditional Boeing design. This project imitates the exterior design of the nose part of B737-300, visible out of the hangar in the nose out direction, employing the use of Cinema 4D, Sketch Up and aircraft reduction formula for dimensions and modelling of the aircraft. Metal ribs was used to construct nose structure in a proportionally reduced manner, and plaster of Paris is used to give it a proper shape. For the final look, fiber reinforced polymer has been used for aircraft manufacturing. Nose wheels are constructed as per reduced dimensions, and a bricked hanger textured wall is planned to imitate the hangar.

Acknowledgment

We express our profound gratitude to the Almighty, the definitive guide, for conferring his blessings upon us throughout our effort. We extend our sincere gratitude to Sir Kalim-ur-Rehman, a Senior Instructor in the IAS department, for all his cooperation with our project. His overall direction and guidance have been responsible for the efficacious accomplishment of our project.

Secondly, we extend our deepest gratitude to Mr. Omer Aziz Tipu, President of SMAP (Scale Model Association of Pakistan) for his unwavering support and guidance throughout our practical project. His expertise and assistance in the practical work were invaluable in helping us understand and apply the calculations to imitate the original model perfectly. We are also truly grateful to our respected instructors who guided us in our project. Thank you for being an integral part of our learning journey.

Table of Contents

1	Introduction	1
1.1	Problem Statement.....	3
1.2	Objectives.....	3
2	Literature review	5
3	Methodology	8
3.1	Selection of Vendor	8
4	Analytical Analysis	9
4.1	Nose part of aircraft.....	10
4.1.1	Horizontal Length from dome to Fuselage.....	11
4.1.2	Vertical length of Fuselage	12
4.1.3	Distance from Nose tip to Nose Landing Gear wheels.....	13
4.1.4	Length and Width of Front Door.....	13
4.2	Windshield.....	16
4.2.1	Window 1 (Right)	16
4.2.2	Window 2 (Right)	17
4.2.3	Window 3 (Right)	18
4.3	Pitot tube	18
4.4	Nose Landing Gear	19
4.4.1	Use of Nose Landing Gear	20
4.4.2	Length of Nose Landing Gear	21
4.4.3	Length of Nose Landing Gear Tires	23
4.4.4	Nose Landing Gear Axle between Tires	24
4.4.5	Nose Landing Gear Main Arm	25
4.4.6	Nose Landing Gear arm 05.....	27
4.4.7	Nose Landing Gear arm 06.....	28
4.5	Hangar-Textured Wall	32
4.6	Warning Lights	30
4.7	Logo	31
5	Fabrication	32
5.1	Nose.....	33
5.1.1	Rings.....	33
5.1.2	Joining of rings.....	33

5.1.3	Distance between outer and front ring	33
5.1.4	Windshield	34
5.1.5	Front Door.....	35
5.1.6	Assembly of nose structure.....	35
5.2	Assembling of Nose Landing gear.....	36
5.3	Riveting	37
5.4	Selection and application of Paint	38
5.4.1	Selection of color scheme.....	38
5.4.2	Application of Paint	39
5.5	Hanger-Textured Wall	39
5.6	Warning Light	39
5.7	Logo	40
5.8	Assembled Aircraft	40
6	Conclusion	42
7	Limitations.....	42
8	Recommendations	43
9	References.....	45
	Appendix A-Reference Drawings.....	47

List of Tables

Table 1-1	Specifications of actual B737-300	2
Table 4-1	- Horizontal length from nose tip to fuselage	12
Table 4-2	- Vertical length of fuselage exterior	12
Table 4-3	- Distance from dome to wheels	13
Table 4-4	- Length of front door	14
Table 4-5	Width of Front Door	15
Table 4-6	- Dimension of Pitot Tube	19
Table 4-7	- Overall dimension of nose landing gear of Boeing 737-300	21

List of Figures

Figure 4-1	- The structure tree.....	10
Figure 4-2	- Length of B737-300 from nose tip to fuselage (Reduced).....	11
Figure 4-3	- Vertical length of fuselage exterior (Reduced)	12
Figure 4-4	- Distance from nose tip to Nose Landing Gear (Reduced)	13
Figure 4-5	- Length of front door (Reduced)	14

Figure 4-6 -Width of front door (Reduced)	15
Figure 4-7 Reduced Window Layout.....	16
Figure 4-8 - Dimensions of Window 1 (Reduced)	16
Figure 4-9 - Dimensions of Window 2 (Reduced)	17
Figure 4-10 - Dimension of Window 3 (Reduced).....	18
Figure 4-11 Pitot tube (original)	19
Figure 4-12 - Nose Landing Gear of Boeing 737-300 (Original)	20
Figure 4-13 - Actual depth of nose landing gear of Boeing 737-300	21
Figure 4-14 - Reduced depth of the nose landing gear of Boeing 737-300	22
Figure 4-15 - Length and width of tires of nose landing gear (Original)	23
Figure 4-16 - Reduced tires length of Boeing 737-300	24
Figure 4-17 - Landing gear axle between tires	24
Figure 4-18 - Reduced axle between tires of NLG.....	25
Figure 4-19 - Actual nose landing gear main arm length	26
Figure 4-20 Reduced nose landing gear main arm length	26
Figure 4-21 - nose landing gear arm 05 (Original)	27
Figure 4-22 - Reduced nose landing gear arm 05	28
Figure 4-23 - Nose landing gear arm 06 (original)	29
Figure 4-24 - Reduced nose landing gear arm 06	29
Figure 4-25 Hanger-Textured Wall	32
Figure 4-26 Actual Obstruction lights.....	30
Figure 4-27 - Warning lights designed in illustrator.....	31
Figure 4-28 - IAS-UMT Department logo	31
Figure 5-1 - B737-300 Nose skeleton	34
Figure 5-2 - Plaster of Paris structure B737-300	36
Figure 5-3 Assembled Nose Landing gear Boeing 737-300	37
Figure 5-4 Riveting design of Boeing 737-300.....	38
Figure 5-5 Pitot Tube (Reduced)	38
Figure 5-6 - Color scheme of B737-300 mockup	39
Figure 5-7 Physical 3D model of Project Plan	41

1 Introduction

Designing and manufacturing commercial aircraft plays a major role in boosting the economy of any country. Overall, the aircraft manufacturing industry can have a positive impact on the economy of a region or country by creating jobs, driving economic growth, and supporting technological and infrastructure development. Pakistan has a small but growing aircraft manufacturing industry. In recent years, the Pakistani government has made efforts to boost the country's aircraft manufacturing industry, including through partnerships with foreign companies and the establishment of a dedicated aircraft manufacturing facility in Karachi. Pakistan has one main aircraft manufacturing organization, Pakistan Aeronautical Complex (PAC), and some small private companies manufacture aircraft prototypes. Overall, the aircraft manufacturing industry in Pakistan is small but growing, and it has the potential to contribute to the country's economic development and technological advancements (Pakistan Aeronautical Complex, 2023).

The replica used for this project is a scale model of a [Boeing737-300]. The selection of Boeing aircraft for Final year Project is made based on unique history of Boeing. Boeing has manufactured variety of products from building biplanes to developing rockets (Boeing Company, 2023).

The Boeing 737 is one of the most well-known aircraft worldwide. By the middle of 2020, it still had the most delivered airplanes. It has undergone several changes since its first flight in 1967, each of which has enhanced and updated its service. Since then, it has gone through four generations with numerous improvements. A well-engineered aircraft structure and continual evolution have supported its success in meeting airline expectations. Of course, as new engines were introduced in subsequent generations, they have evolved with the times and now function more effectively to preserve a competitive advantage (HAYWARD, 2020).

The 737-100 introduced the usage of twin engines. Boeing chose the JT8D low-bypass engines from Pratt & Whitney. It had a smaller capacity than any model that came after it, with an average two-class capacity of just 85. In a flash, the 737-200 followed the 737-100. The most significant difference, which United requested and most airlines preferred, was an expanded fuselage. There are 102 available regular seats (and a limit of 136). Additionally, JT8D engines were upgraded with higher thrust. (HAYWARD, 2020).

Later, Boeing upgraded the 737 in various ways for the next generation. The 737-300 was the Classic series' first model in 1984. Although there were several changes and improvements, it is essential to remember that the new models still had many features in common with the older models (in terms of design and flight operation). The Classic series main developments were the capacity and fuel as given in the Table 1-1 which increases economy (Boeing Company, 2023).

Table 1-1 Specifications of actual B737-300

Model	CFM56-3
Type	B2
Thrust	88.9 knots
Aircraft Length	109 ft.
Fuselage height	13 ft.
Fuselage width	12 ft.
Cabin width	11 ft.
Wing span	94 ft.
Aircraft height	36 ft.
Wheel base	40 ft.
No of nose wheel	2
Max certified seating	149
Typical seating	149
Fuel capacity	20105 L
Range with Max payload	5,463 Km
Probe; pitot, static	1.25 x 11.875 x 5.75 IN

The Boeing 737-300 was selected for its flawless resemblance to earlier Boeing models. Secondly, 300 is smaller than most recent versions, making it relatively easier to construct (737 COMMERCIAL TRANSPORT, 2023).

Rising aircraft manufacturing demand requires countries to encourage youth towards this side. Overall, encouraging students to study aircraft design can help to prepare them for rewarding careers in this field, support the growth of the aircraft manufacturing industry, and contribute to economic and technological advancement. This 3D mock-up would be a

permanent asset for public awareness and passion among students to come forward in such activities.

1.1 Problem Statement

In Pakistan, the model Boeing 737-300 nose is innovative as no vendor or institute has made it before. To reduce the aircraft measurements towards the nose, we implied two methods. In the scale-down method aircraft's reduced dimensions are obtained manually using a calculator. The major challenge here was calculation can't be very effective to get a perfect shape. 3D software, SketchUp is used to get complete dimensions. A three-dimension model is designed on, which amplifies the measurements in a more precise and efficient way. Using 3D modelling helped us and manufacturer make an accurate model of the Boeing 737-300 aircraft.

Furthermore, it is challenging to effectively design and manufacture a full-scale mockup of an airliner that accurately represents the final production aircraft in terms of layout, and design, while also meeting project cost and schedule constraints. This problem statement outlines the key challenges and objectives that need to be addressed in the manufacturing a B737-300 airliner mockup of 60 inches diameter, including the need for accuracy and cost effectiveness. The project aims to teach students the importance of teamwork and communication in the aerospace industry and appreciation for the complexity and attention to detail required in aircraft design and manufacturing.

1.2 Objectives

- I. This project aimed to create a visually accurate and aesthetically pleasing replica of the B737-300.
- II. The primary objective of the project was to give students hands-on experience in building and analyzing the structure of an aircraft. The mockup provided students with the opportunity to work with materials and techniques used in the aerospace industry, and to understand the principles of aircraft design and construction.
- III. The mockup project aimed to give students an appreciation for the complexity and attention to detail required in aircraft design and

manufacturing. By building the mockup, students were able to understand the challenges and considerations that go into designing and building a real aircraft.

- IV. To create awareness among the public and Institute of Aviation Studies students.
- V. To create an accurate and one of the most significant B737-300 models first time in Pakistan and assemble all the components of Boeing to fabricate effectively.
- VI. The project also aimed to teach students the importance of teamwork and communication in aerospace industry. Students worked in teams to complete the mockup, and had to communicate effectively to ensure that the project was completed on time and to the highest standards.
- VII. This mockup can be used to test and evaluate new technologies and systems, allowing students to research and develop new ideas and concepts on aircraft design and modeling.
- VIII. The mockup will be a valuable resource for future aviation courses at the university.

2 Literature review

In the past many mockups of aircraft nose were made, Russia's UAC and China Comac has jointly developed nose mockup of CR929 widebody jetliner to showcase the design and layout of the interior cabin with to demonstrate the collaboration between the two companies in the aerospace industry (CR929 Mockup Unveiled at Airshow China 2018, 2018). Another mockup was created as part of the development process for a Lockheed aircraft (Lockheed Polaris [mfr via RJF], 2015). Manufacturing of these mockup similar to real product is very complex process.

In recent ages, using computer-aided designs (CAD) has become increasingly predominant in the aerospace industry, as it allows for more efficient and accurate design processes, as well as the ability to easily make changes and adjustments to the design. The use of software such as SketchUp, SolidWorks, and CATIA has been widely used in the design and development of aircraft. Several studies have investigated the use of Sketch Up software in the aerospace industry. For example, (Fabian, 2017) found that the use of SketchUp in the design of a commercial airplane led to a significant reduction in the time and cost of the development process.

(Brightman, 2018) Stated that the use of SketchUp in the design of aircraft wing structures led to a significant reduction in weight and an increase in aerodynamic performance. Furthermore, it was found that the use of SketchUp in the design of aircraft fuselage led to a significant reduction in manufacturing costs.

(Mas, Ríos, Gómez, & Hernández, 2016), in the research study it is stated that the use of a knowledge-based applications in aircraft final assembly lines makes the outcome more precise. The application uses a knowledge base of information about aircraft assembly processes and techniques to assist in the design and planning of assembly lines. As stated in this study the goal of the application is to improve the efficiency and effectiveness of aircraft assembly line design, and to reduce the time and costs associated with the design process. This study suggests that the use of a knowledge-based CAD system can provide significant benefits to companies involved in aircraft manufacturing by improving the efficiency and effectiveness of assembly line design.

(Egorova & Shcherbinin , 2016), In the study "Creating technical heritage object replicas in a virtual environment" presents a methodology for creating virtual replicas of technical heritage objects like aircrafts or ships, using a combination of 3D scanning, photogrammetry and Computer-Aided Design (CAD) techniques.

The authors begin by discussing the importance of preserving technical heritage objects and the challenges involved in preserving these objects in a physical environment. This study also highlighted the use of CAD techniques to create detailed and accurate virtual models. It was also suggested that virtual mockups could be used not only in the engineering and development process but also in education and research.

(TAYLOR, 1995) Stated in the book "Centrifuges in Modelling: Principles and Scale Effects" provides valuable information on the use of centrifuges in modeling and the effects of scale on the results. The book discusses the use of the scale-down method as a technique for creating smaller, more manageable models of full-scale aircraft. This method involves reducing the size of the model while maintaining its proportion and main characteristics. The book states that the scale-down method is widely used in the aerospace industry as it allows for a cost-effective way of testing and evaluating aircraft models. The smaller-scale models are used to test and evaluate the structural integrity, aerodynamics, and other functional characteristics of the aircraft.

(Funke, 1997) Discussed the concept of concurrent engineering and its relationship to the development process in the aircraft industry. Concurrent engineering is a method of designing and developing products in which all aspects of the product are considered simultaneously, rather than sequentially. The article notes that this approach can lead to significant improvements in the efficiency and effectiveness of the development process. The article also mentions some of the challenges associated with implementing concurrent engineering in the aircraft industry, such as the need for interdisciplinary teams, effective communication, and advanced technology.

In the aircraft manufacturing industry, the fabrication of mockups is an important aspect of the design and development process of aircraft. Mockups are used to test and evaluate various design elements and systems before the actual construction of the aircraft. There have been several studies that have investigated the fabrication of mockups in the aerospace industry, with a focus on the materials and manufacturing techniques used. For example, (MRAZOVA, 2013) A study suggests that advanced composite materials have the potential to play a significant role in shaping the future of the aerospace industry, by providing greater strength and durability, as well as the ability to create complex geometries, reduce waste and enhance performance and safety. Unconventional composite materials being used in the fabrication of a mockup of a military aircraft led to a significant reduction in weight and an increase in strength and durability.

(Caggiano, Marzano, & Teti, 2016), In the research study discussed that well-organized configuration of the aircraft assembly line is critical to manufacturing of aircraft. This paper says that properly configured tasks in assembly line can made contribution in the profitability of final products and the competitiveness of manufacturing industries. Appropriate practices and methods, such as design for manufacture and assembly, sequence of assembly, and optimized performances, can support an effective configuration of assembly line. It is also stated that a more complex and specified process sequence is required to include all the necessary assembly operations, details for the individual lines, and a final cell layout developed in the sequence of assembly line. The primary assembly sequence was decomposed into the following operations: Loading, Drilling, Riveting, unloading, and inspecting.

(Megson, 2018) Explained the process of structural analysis in aircraft design. It is a fundamental step in the aircraft design process, it uses different techniques such as 3D printing, CNC machining, and hand sculpting to create the mockup for testing, and verifying the design before it is put into production. As it is explained that the structural analysis process involves analyzing the loads and stresses that an aircraft will experience during its operation and determining the strength and stiffness of the structural components. The book also covers the process of aircraft manufacturing, including the cutting, shaping, and joining of structural components, as well as the application of coatings and finishes to protect the aircraft from the elements. The author also stresses the importance of quality control and testing in the manufacturing process to ensure that the aircraft meets the required specifications.

Overall, the literature suggests that the use of software for computer-aided design and reduction factors in the construction of mockups can have significant benefits in terms of efficiency, accuracy, and cost-effectiveness. In addition, it suggests that a reduction factor is a scale that is applied to the dimensions of the mockup to make it smaller than the actual aircraft. This allows for the mockup to be more manageable and easily transportable for testing and evaluation purposes, while still maintaining a high level of accuracy and functionality. Furthermore, it suggests that fabrication is one of the important aspects of aircraft. Before the actual construction of the aircraft various design elements and systems requires tests and evaluation. 3D Mockups provide a realistic representation of the aircraft, allowing engineers and designers to make changes and adjustments to the design in a cost-effective way.

3 Methodology

The goal of this project was to create a visually accurate mockup of the B737-300. In the first step of methodology research was conducted on the Boeing 737-300 aircraft. Data from various sources was gathered regarding dimensions, design, and features of the aircraft.

In the next step, scale of 1:2.5 was used at which the mockup is created. The dimensions of the real Boeing 737-300 were scaled down to a manageable size for the mockup by using Scale Calculator. Furthermore 3D file of original B737-300 is inserted in 3D modeling software “SketchUp” to obtain dimensions with accurate dimensions and proportions. The fourth step was to add details and textures to the mockup using Illustrator, a vector graphics software. This included adding markings, labels, and other details to the mockup to make it look as realistic as possible.

The final step was to test the mockup for accuracy and realism. This included comparing the mockup to pictures and drawings of the real Boeing 737-300 to ensure that it was as accurate as possible.

3.1 Selection of Vendor

Selection of vendor for constructions of B737-300 mockup is made on the bases of their past experience, quality, lead time, cost and support. On the bases of this criteria 4 vendors were shortlisted. Among the shortlisted vendors some had experience in Fiber mockups and some on metal mockups. Visit on their workshops were arranged where all the members analyzed them on the bases of selected criteria and their personal opinion. Furthermore, with the collaborative effort 1 vendor was selected among them because his previous works on Fiber mockups was liked by each member. Selection of the vendor was made on following qualities:

- I. Vendor had a proven track record in producing high quality mockups. E.g. helicopter made for army person and eagle on Walton road, Lahore.
- II. Vendor has the ability to produce mockup that meets the required specifications and standards.
- III. Cost of mockup must be competitive while ensuring quality.
- IV. Vendor must be able to deliver the mockup within the specified time frame.
- V. The vendor must be able to provide ongoing support and maintenance for the mockup.

4 Analytical Analysis

This report presents an analysis of a mock-up of a Boeing 737-300 that was constructed using SketchUp software and a reduction factor for dimensions. First of all structure tree for project was created as it is shown in the *fig 4-1* to categorize important elements of mockup construction. The mock-up was created as a tool for testing and evaluating various design elements and systems before the actual construction of the aircraft. The use of Sketch Up software allowed for a more efficient and cost-effective construction process, as well as the ability to easily make changes and adjustments to the design. The reduction factor for dimensions was applied to the mock-up to get a reduced version of the original B737-300.

The report begins by providing an overview of the mock-up construction process, including the use of SketchUp software and the application of the reduction factor for dimensions. The steps involved in sketchup to reduce the required dimension are in the sequence of; Selection tool > Select the model > Scale Tool > Scale down the model as required by drag and drop from the corner points to complete the process. The results of these evaluations are discussed, along with any adjustments and improvements that were made to the design as a result.

Finally, the report concludes with a summary of the overall effectiveness of the mock-up in the design and development process of the 737-300 and the benefits of using Sketch Up software and reduction factor for dimensions in the mock-up construction process.

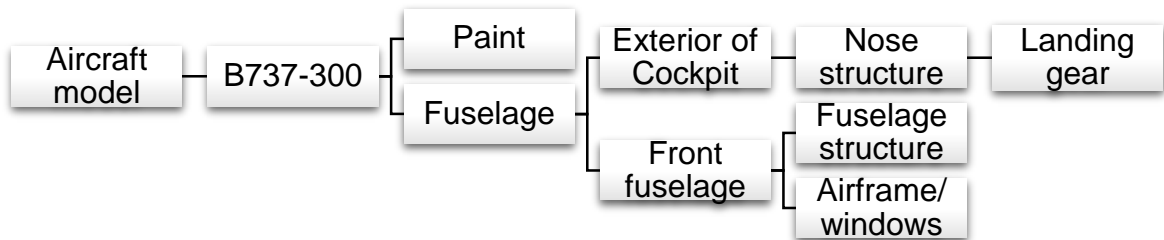

Figure 4-1 - The structure tree

4.1 Nose part of aircraft

The exterior of the nose and cockpit of an aircraft are important components that serve a variety of functions. There is a list of components that we constructed in the exterior of the nose and cockpit of an aircraft mockup include:

- I. The windshield is a transparent panel at the front of the cockpit that allows the pilots to see out of the aircraft. It is made of strong, scratch-resistant material and is designed to withstand the extreme forces of flight.
- II. The nose cone is the pointed or rounded structure at the front of the aircraft that helps to reduce drag and improve the aerodynamics of the aircraft.
- III. Landing lights are typically located on the underside of the nose of an aircraft and are used to illuminate the runway during takeoff and landing.
- IV. The Pitot tube is a small, pointed probe located on the nose or wing of an aircraft that measures the airspeed of the aircraft.
- V. The nose wheel is a small wheel located at the front of the aircraft that is used to steer the aircraft during ground movement.

First of all, horizontal and vertical dimensions of the original B737 300 are used to obtain the required measurements for the construction of the model. The actual length of the dome to the fuselage is 17.5 feet of the original B737 300. The cross-sectional or vertical height of is fuselage exterior is 13.2 feet. These actual dimensions are being used in the scale calculator to get reduced dimensions for

our model. A scale of 1:2.5 has been used to obtain the required measurements. Our model is 2.5 times smaller than the actual aircraft. Therefore, the ratio we have calculated is 1:2.5 on the scale calculator.

4.1.1 Horizontal Length from dome to Fuselage

The horizontal length of the original aircraft from the nose tip to the specified point was 210 inches (17.5 ft.). The length was reduced by using the "Scaling tool" in the "Sketch Up" App. The value of the actual length which is 210 inches (17.5 feet) is entered into the calculator to obtain a reduced length for the mock-up which is 84 inches (7 feet) as in Fig 4-2. The ratio between the original and the reduced value is 2.5.

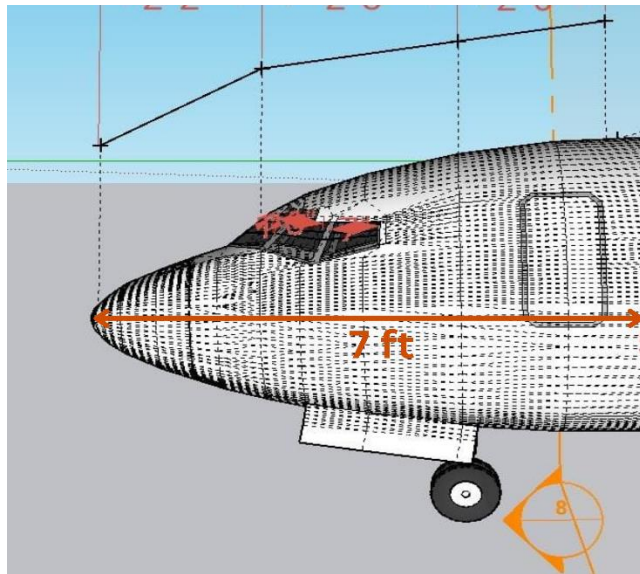

Figure 4-2 - Length of B737-300 from nose tip to fuselage (Reduced)

To find the Horizontal length of the nose from the nose tip to the fuselage again the same method is used inside the scale calculator. The Horizontal length of an Actual Boeing 737-300 is 210 inches (17.5 feet). Therefore, the horizontal length of the dome to the fuselage is 84 inches (7 feet) of mockup, which is calculated as in Table 4-1. The reduced model of B737 300 is obtained from the actual one by scale-down method. Therefore, the horizontal length is also 2.5 times smaller than the actual aircraft.

Table 4-1 - Horizontal length from nose tip to fuselage

Original	Reduced	Scale Down
210 inches (17.5 feet)	84 inches (7 feet)	1: 2.5

4.1.2 Vertical length of Fuselage

The vertical length of the original aircraft from the nose tip to the specified point was 158.4 inches (13.2 feet). The length was reduced by using the "Scaling tool" in the "Sketch Up" App, the actual length of 158.4 inches (13.2 feet) was added and got reduced length for the mock-up to 60 inches (5 feet) as in Fig 4-3. The ratio between the original and the reduced value is 2.5.

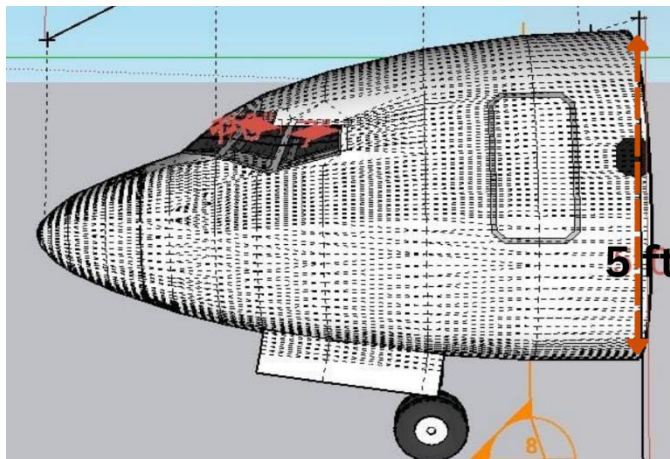

Figure 4-3 - Vertical length of fuselage exterior (Reduced)

The Vertical outer length of the actual aircraft is 13.2 feet (158.4 inches) and the vertical outer length of the model is 5 feet (60 inches) as in Table 4-2. By using a scale calculator, the original model of B737 300 was reduced proportionally. Vertical length is also 2.5 times smaller than actual aircraft.

Table 4-2 - Vertical length of fuselage exterior

Original	Reduced	Scale Down
158.4 inches (13.2 feet)	60 inches (5 feet)	1: 2.5

4.1.3 Distance from Nose tip to Nose Landing Gear wheels

The actual distance from the nose tip to the Nose Landing Gear wheel is 150 inches (12.5 feet). The length was reduced by using the "Scaling tool" in the "Sketch Up" App, the actual length of 150 inches (12.5 feet) was added and got reduced length for the mock-up to 60 inches (5 feet) as in Fig 4-4. The ratio between the original and the reduced value is 2.5.

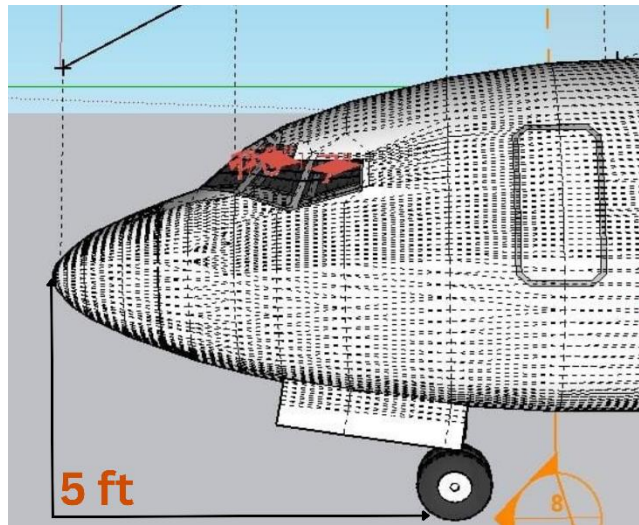

Figure 4-4 - Distance from nose tip to Nose Landing Gear (Reduced)

The distance from the dome to the wheels of the actual aircraft is 150 inches (12.5 feet). By using a scale calculator, the distance obtained from the dome to the wheels of the model is 60 inches (5 feet) as in Table 4-3. It is 2.5 times smaller than the actual aircraft dimension.

Table 4-3 - Distance from dome to wheels

Original	Reduced	Scale Down
150 inches (12.5 feet)	60 inches (5 feet)	1: 2.5

4.1.4 Length and Width of Front Door

The actual length of the door was 82.44 inches (6.87 feet). The length was reduced by using the "Scaling tool" in the "Sketch Up" App, an actual length of 82.44 inches (6.87 feet) was added, and got reduced length was 33 inches (2.75 feet) as in Fig 4-5. The ratio between the original and the reduced value is 2.5.

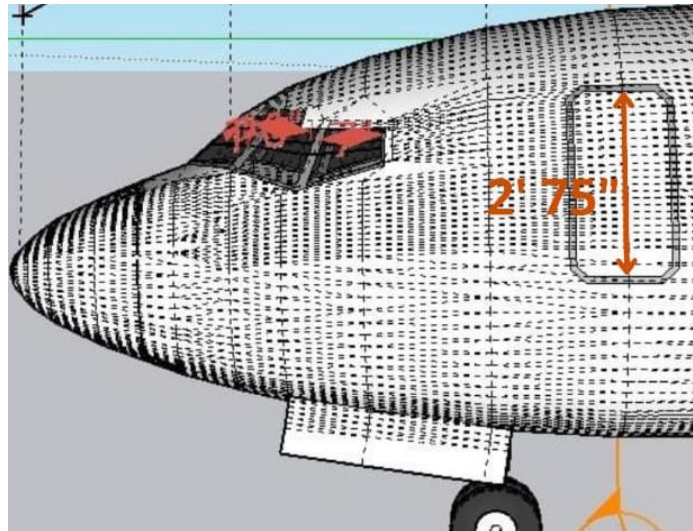

Figure 4-5 - Length of front door (Reduced)

The length of the front door of the actual Boeing 737 300 is 82.44 inches (6.87 feet). The model length is 33 inches (2.75 feet) calculate on a scale calculator by the scale-down method as in Table 4-4.

Table 4-4 - Length of front door

Original	Reduced	Scale Down
82.44 inches (6.87 feet)	33 inches (2.75 feet)	1: 2.5

The actual width of the door was 42 inches (3.5 feet). The length was reduced by using the "Scaling tool" in the "Sketch Up" App, actual width of 42 inches (3.5 feet) was added, and got reduced width was 16.8 inches (1.4 feet) as in Fig 4-6. The ratio between the original and the reduced value is 2.5.

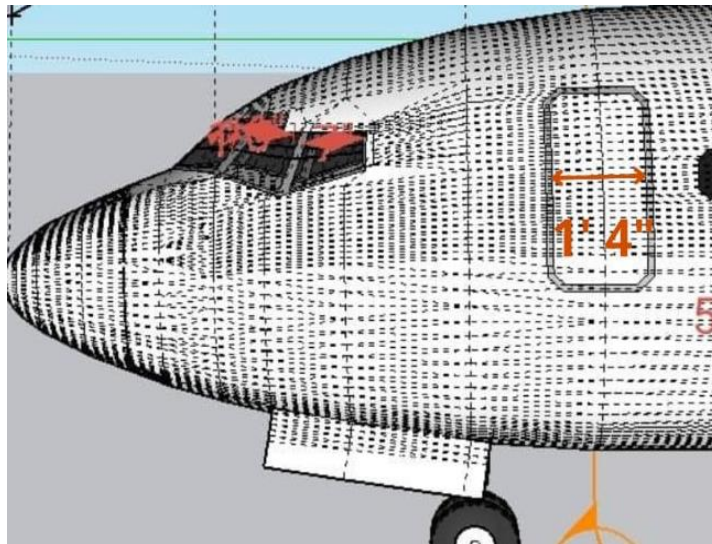

Figure 4-6 -Width of front door (Reduced)

The width of the front door of the actual B737 300 is 42 inches (3.5 feet), and the width of the model is 16.8 inches (1.4 feet) calculated by using a scale calculator on the scale-down method as in Table 4-5.

Table 4-5 Width of Front Door

Original	Reduced	Scale Down
42 inches (3.5 feet)	16.8 inches (1.4 feet)	1: 2.5

4.2 Windshield

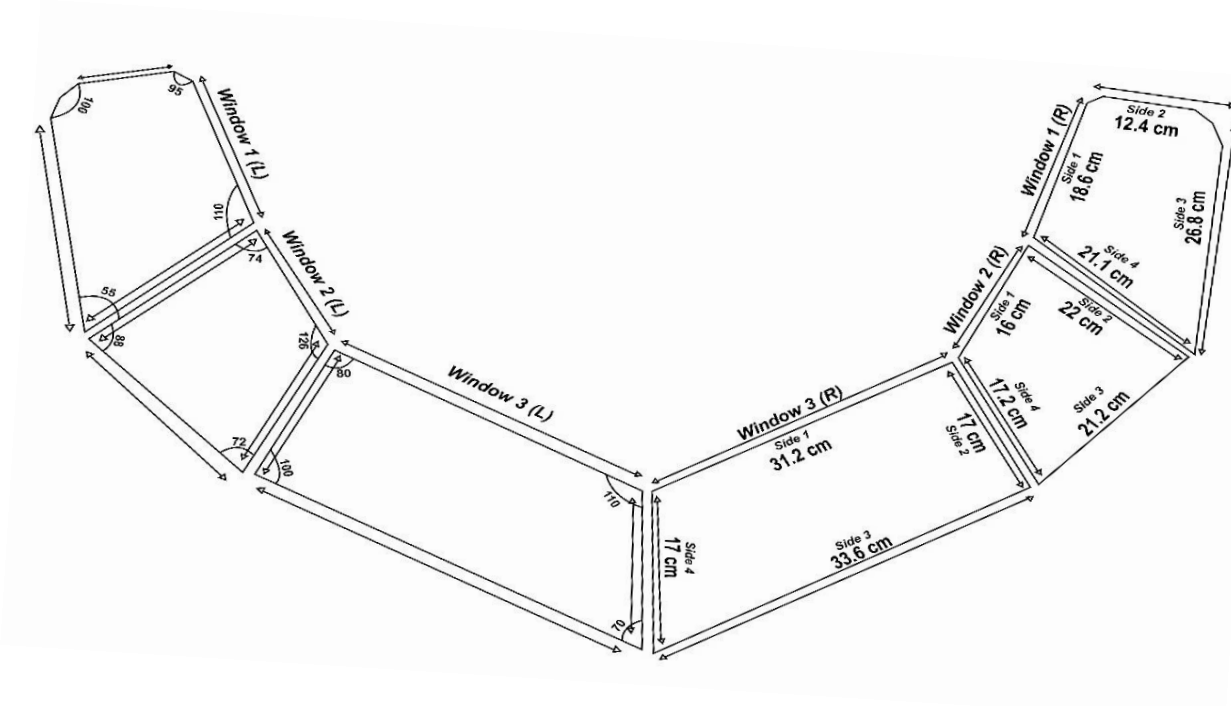

Figure 4-7 Reduced Window Layout

4.2.1 Window 1 (Right)

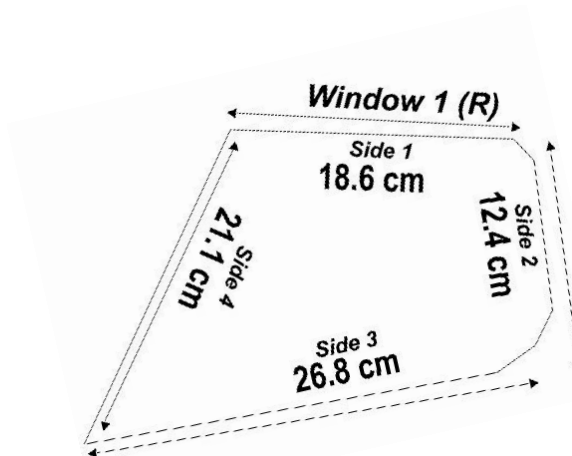

Figure 4-8 - Dimensions of Window 1 (Reduced)

The actual length of the side-1 of window 1 (R) is 46.5 cm (18.3 inches) and by using a scale calculator, the reduced value is 18.6 cm (7.32 inches) according to the 1:2.5 scale. The actual length of the side-2 of window 1 (R) is 31 cm (12.20 inches) and by using a scale calculator, the reduced value obtained is 12.4 cm (4.88 inches) according to the 1:2.5 scale.

The actual length of the side-3 of window 1 (R) is 67 cm (26.37 inches) and by using a scale calculator, the reduced value obtained is 26.8 cm (10.55 inches) according to the 1:2.5 scale. The actual length of the side-4 of window 1 (R) is 53 cm (20.866) and by using a scale calculator, the reduced value is 21.2 cm (8.34 inches) according to the 1:2.5 scale as shown in *Fig 4-8*.

4.2.2 Window 2 (Right)

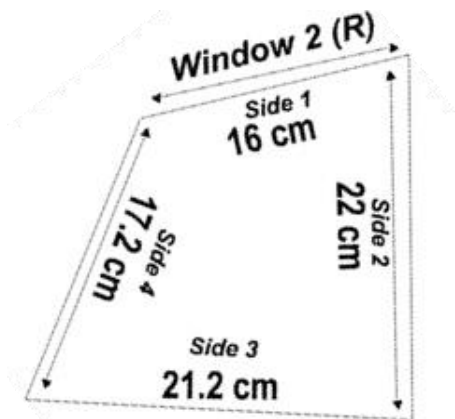

Figure 4-9 - Dimensions of Window 2 (Reduced)

The actual length of the side-1 of window 2 (R) is 40 cm (15.74 inches) and by using a scale calculator, the reduced value is 16 cm (6.29 inches) according to the 1:2.5 scale. The actual length of side-2 of window 2 (R) is 55 cm (21.6 inches) and by using the scale calculator, the reduced value obtained is 22 cm (8.6 cm) according to the 1:2.5 scale.

The actual length of side-3 of window 2 (R) is 53 cm (20.8 inches) and by using a scale calculator, the reduced value attained is 21.2 cm (8.34 inches) according to the 1:2.5 scale. The actual length of side-4 of window 2 (R) is 43 cm (16.9 inches) and by using a scale calculator, the reduced value obtained is 17.2 cm (6.7 inches) according to the 1:2.5 scale as shown in *Fig 4-9*.

4.2.3 Window 3 (Right)

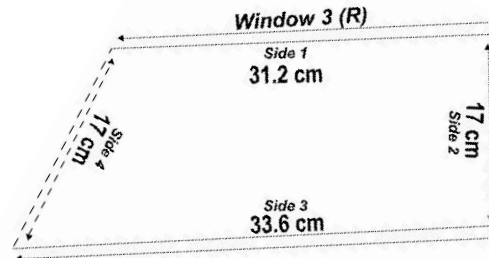

Figure 4-10 - Dimension of Window 3 (Reduced)

The actual length of the side-1 of window 3 (R) is 78 cm (30.7 inches) and by using a scale calculator, the reduced value calculated is 31.2 cm (12.2 inches) according to the 1:2.5 scale. The actual length side-2 of window 3 (R) is 42.5 cm (16.7 inches) and by using a scale calculator, the reduced value is 17 cm (6.6 inches) according to the 1:2.5 scale. The actual length of the side-3 of window 3 (R) is 84 cm (33.0 inches) and by using a scale calculator, the reduced value obtained is 33.6 cm (13.22 inches) according to the 1:2.5 scale. The actual length of side-4 of window 3 (R) is 42.5 cm (16.7 inches) and by using a scale calculator, the reduced value obtained is 17 cm (6.6 inches) according to the 1:2.5 scale as shown in Fig 4-10.

4.3 Pitot tube

The original dimensions of the Pitot tube of actual aircraft are proportionally reduced in the scale calculator. The actual length of the Boeing 737-300 Pitot tube is 20.25 inches (1.68 feet), the width is 11.875 inches (0.98 feet) and the height is 5.75 inches (0.47 feet). By using a scale calculator, reduced values are obtained with a length of Pitot tube is 8.1 inches (0.6 feet), width is 4.75 inches (0.39 feet) and height is 2.3 inches (0.19 feet) as in Table 4-6. (Probe: Pitot,Static, 2023).

Table 4-6 - Dimension of Pitot Tube

Actual	Reduced	Scale Down
(L X W X H) 20.25 x 11.875 x 5.75 inches	(L X W X H) 8.1 x 4.75 x 2.3 inches	1: 2.5



Figure 4-11 Pitot tube (original)

4.4 Nose Landing Gear

Nose landing gear design tends to have some interventions with the aircraft structural design. The landing gear of B737-300 comprises various systems such as brake, shock absorber, and directional maneuver on the runway. The only aircraft part that will be in contact with the ground is the landing gear. To protect the wheels of landing gear from adverse weather and aircraft weight, it was decided to keep the wheels a little up from the ground supported by two metal rods.

During taxiing, landing, and takeoff, the aircraft's landing gear prevents it from sliding over on the ground. Wheels are the most common type of landing gear, but skis, floats, and skids are needed for use on snow, ice, or water, respectively. Faster aircraft can reduce drag by folding away retractable undercarriages while in flight.

4.4.1 Use of Nose Landing Gear

The aircraft's nose landing gear serves as the majority of its support while it is static, taxiing, taking off, or landing. Although aircraft can be equipped with floats for use in water operations and skis for use when landing on snow, wheels are the most used form of the nose landing gear. Smaller aircraft normally have three wheels for their wheeled landing gear: two main wheels that are located on either side of the fuselage and a third wheel that can be placed either in front of or behind the aircraft.



Figure 4-12 - Nose Landing Gear of Boeing 737-300 (Original)

4.4.2 Depth of Nose Landing Gear

The actual depth of the nose landing gear is 171.31 inches (14.2 feet) and the depth is reduced by using the "Scaling tool" in the "Sketch Up" App. The actual depth of 171.31 inches (14.2 feet) as shown in Fig 4-12 was added and was reduced to depth, which is 42 inches (3.5 feet) as shown in Fig 4-13. The ratio between the original and the reduced value is 2.5.

Table 4-7 - Overall dimension of nose landing gear of Boeing 737-300

Depth	Width	Scale Down
171.31 inches (14.2 feet)	76.22 inches (6.35 feet)	1: 2.5

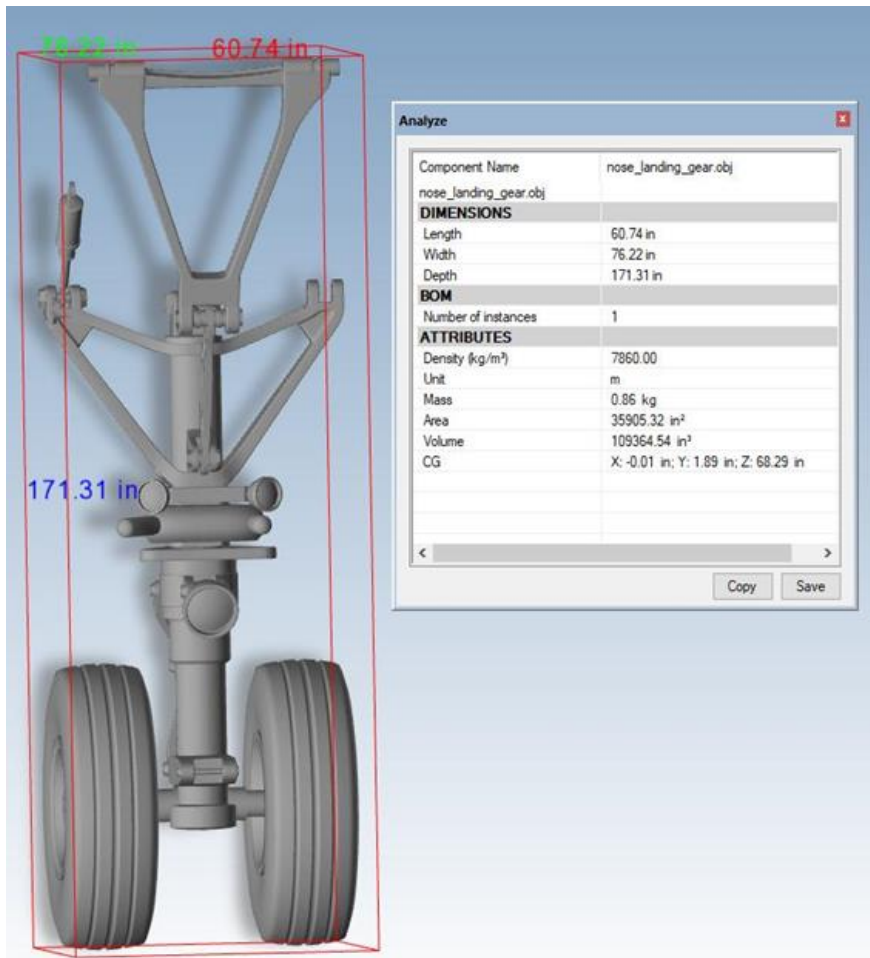

Figure 4-13 - Actual depth of nose landing gear of Boeing 737-300

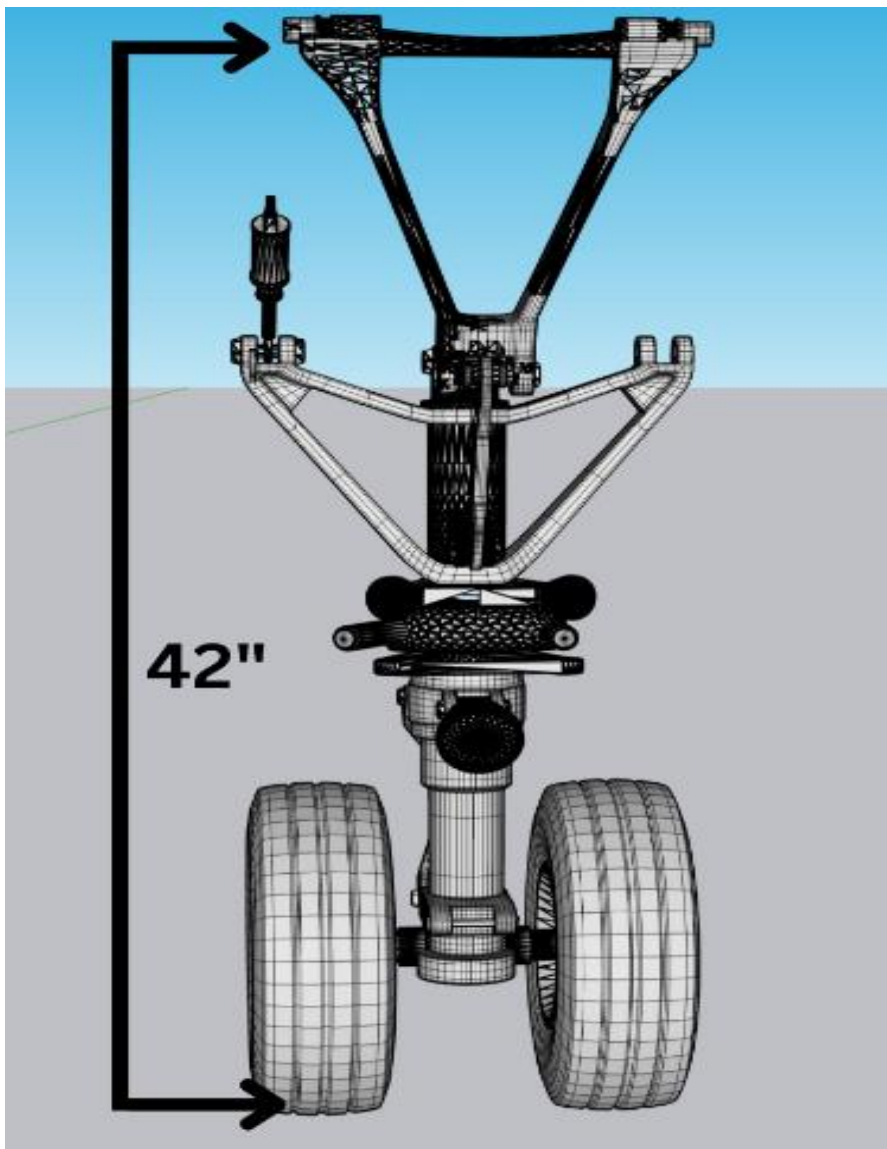

Figure 4-14 - Reduced depth of the nose landing gear of Boeing 737-300

4.4.3 Length of Nose Landing Gear Tires

The actual length of the nose landing gear tire is 58.86 inches (4.9 feet) as shown in Fig 4-15.



Figure 4-15 - Length and width of tires of nose landing gear (Original)

The length was reduced by using the "Scaling tool" in the "Sketch Up" App, actual length of tires is 58.86 inches (4.9 feet) added, and got reduced width was 23.52 inches (1.96 feet). The ratio between the original and the reduced value is 2.5.

By using a scale calculator, the length of the nose landing gear of original Boeing 737 300 is 58.86 inches (4.9 feet) and the model length is 23.52 inches (1.96 feet) as shown Fig 4-16 calculated on a scale calculator according to scale down method

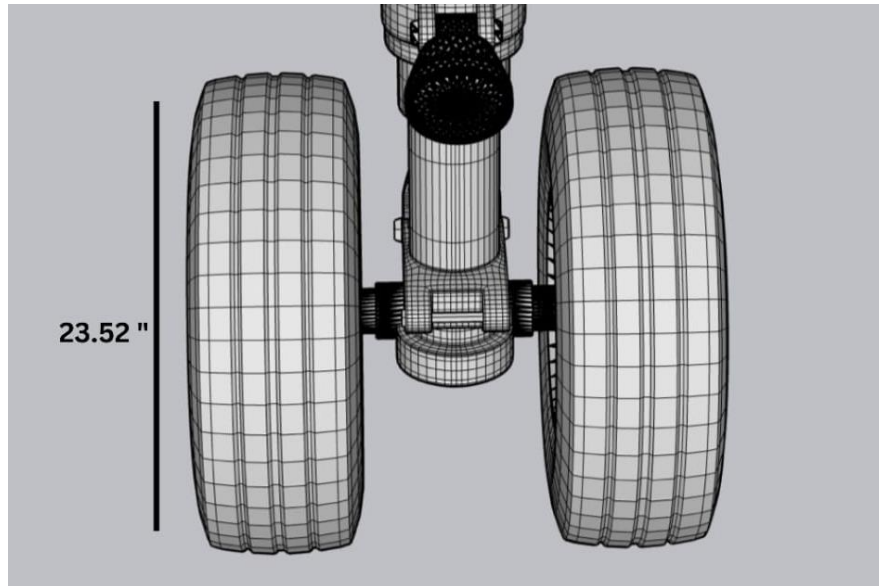

Figure 4-16 - Reduced tires length of Boeing 737-300

4.4.4 Nose Landing Gear Axle between Tires

Actual width of the axle of wheels is 27.6 inches (2.3 feet) as shown in Fig 4-17.



Figure 4-17 - Landing gear axle between tires

The width reduced by using "Scaling tool" in the "Sketch Up" App, actual width between tires is 27.6 inches (2.3 feet) were added and got reduced width was 11.04 inches (0.92 feet) as shown in Fig 4-18. The ratio between with the original and the reduced value is 2.5.

By using scale calculator, length of the nose landing gear of Boeing 737 300 which is 27.6 inches (2.3 feet) is reduced to 11.04 inches (0.92 feet) according to scale down method.

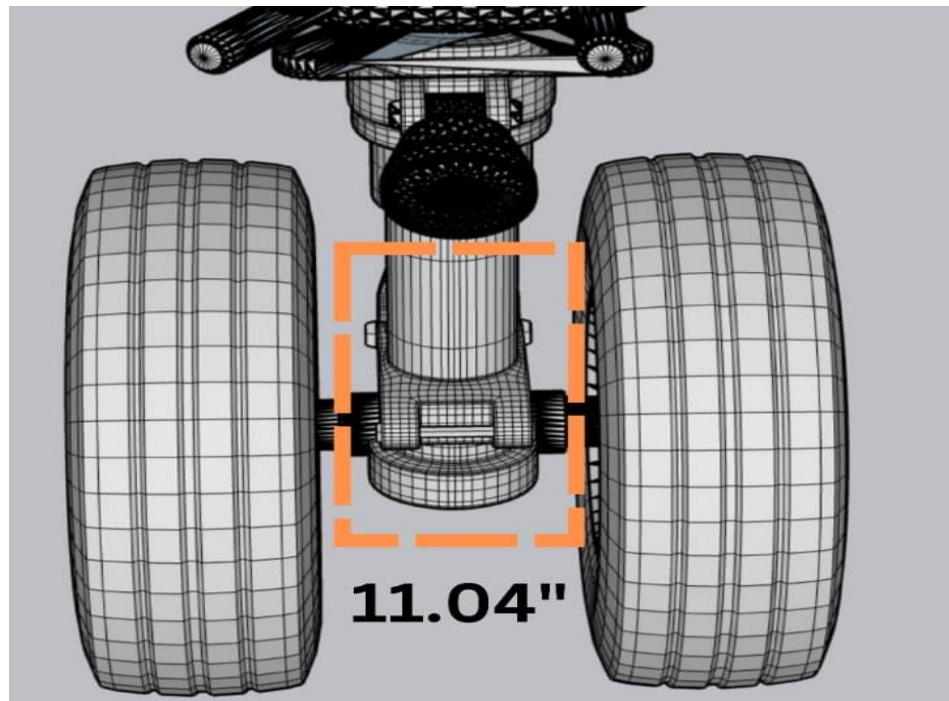

Figure 4-18 - Reduced axle between tires of NLG

4.4.5 Nose Landing Gear Main Arm

The actual length of the nose landing gear main arm is 41.5 inches (3.45 feet). The length was reduced by using the "Scaling tool" in the "Sketch Up" App, the actual length of the main arm is 41.5 inches (3.45 feet) added and got reduced length was 16.6 Inches (1.38 feet) as shown in Fig 4-20 The ratio between the original and the reduced value is 2.5.

Actual length of the nose landing gear main arm is 41.5 inches (3.45 feet). Scale calculator is used to reduce actual length to obtain reduced value of 16.6 inches (1.38 feet) according to scale down method.

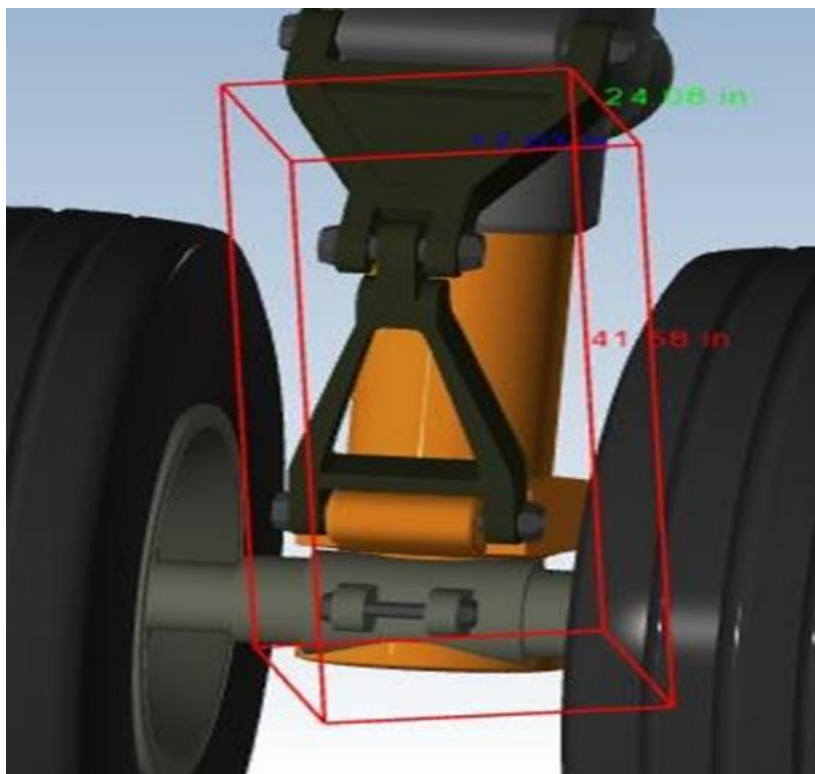

Figure 4-19 - Actual nose landing gear main arm length

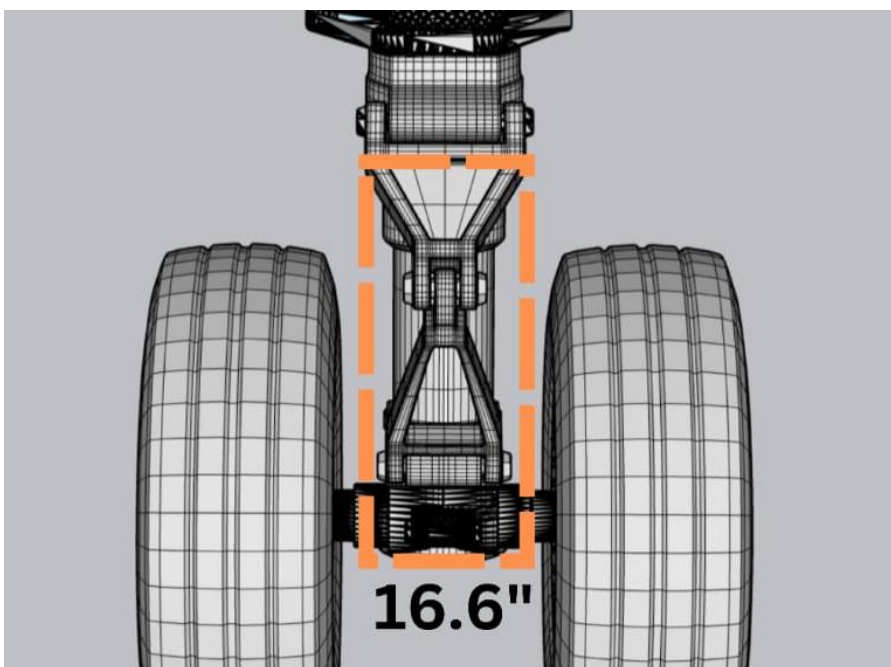

Figure 4-20 Reduced nose landing gear main arm length

4.4.6 Nose Landing Gear arm 05

The actual length of nose landing gear arm 05 is 11.53 inches (0.96 feet). The length was reduced by using the "Scaling tool" in the "Sketch Up" App, the actual length of nose landing gear arm 05 is 11.53 inches (0.96 feet) added, and got reduced width was 4.61 Inches (0.384 feet) as shown in Fig 4-22. The ratio between the original and the reduced value is 2.5.

Actual length of the nose landing gear arm 05 is 11.53 inches (0.96 feet). To obtain a reduced dimension scale calculator is used. Obtained value 4.61 inches (0.384 feet) as per scale down method.

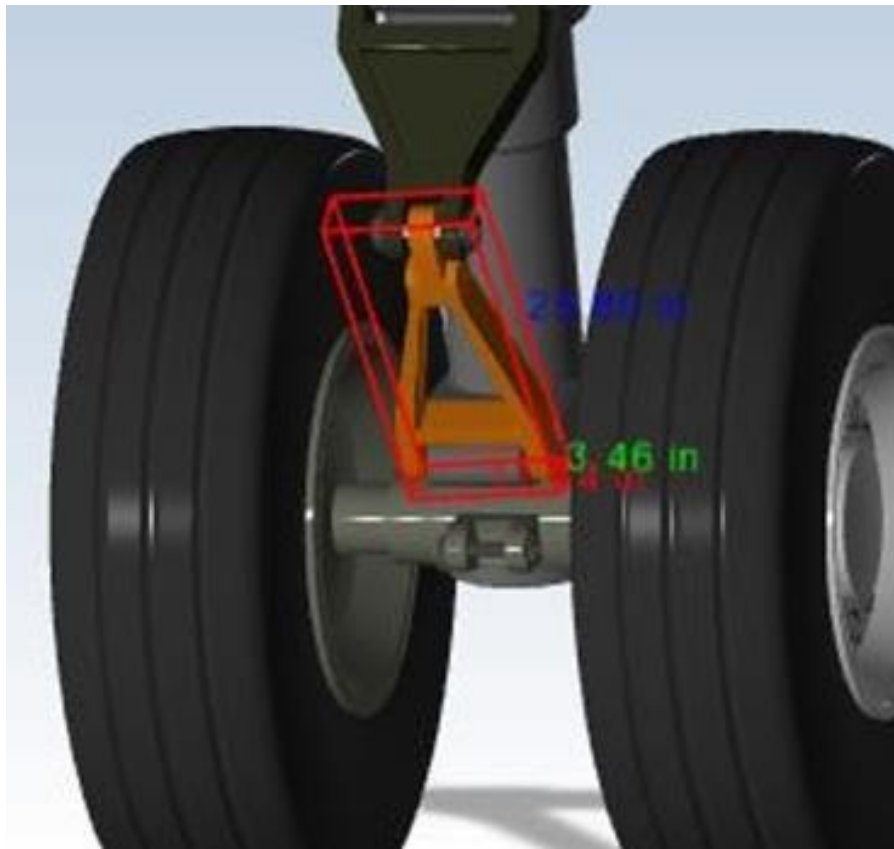

Figure 4-21 - nose landing gear arm 05 (Original)

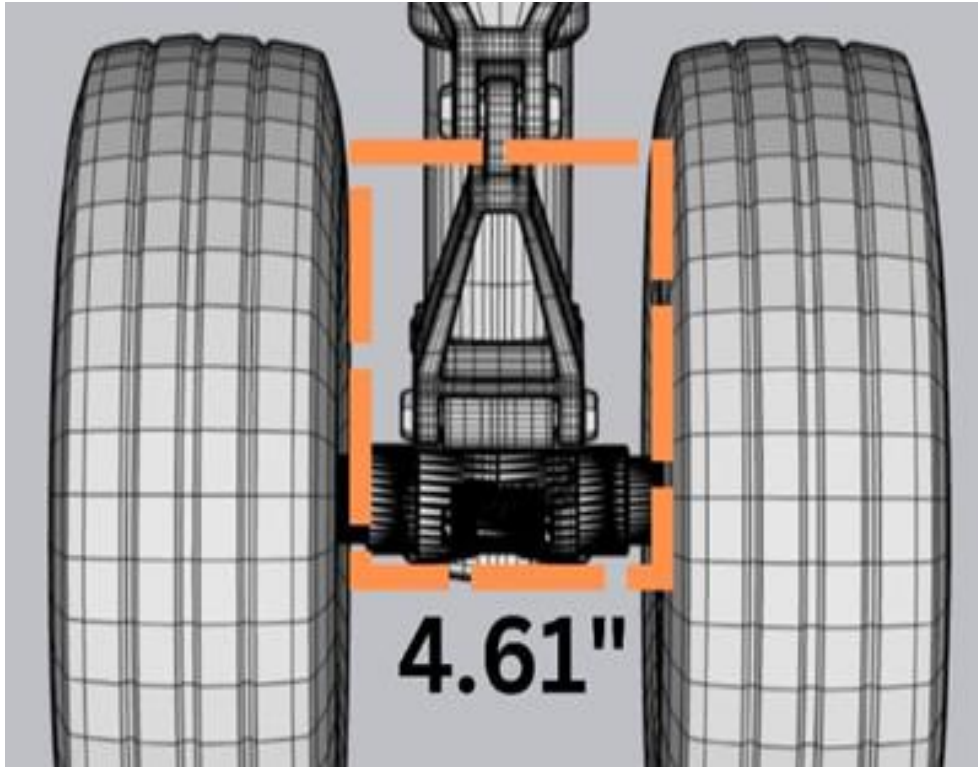

Figure 4-22 - Reduced nose landing gear arm 05

4.4.7 Nose Landing Gear arm 06

The actual length of nose landing gear arm 06 is 59.53 inches (4.96 feet). The length was reduced by using the "Scaling tool" in the "Sketch Up" App, actual length of nose landing gear arm 06 is 59.53 inches (4.96 feet) added, and got reduced width was 33.81 Inches (2.81 feet) as in *Fig 4-24*. The ratio between the original and the reduced value is 2.5.

By using scale calculator, actual length of the nose landing gear arm 06 which is 59.53 inches (4.96 feet) is reduced for model. Obtained length is 33.81 inches (2.81 feet) as per scale down method

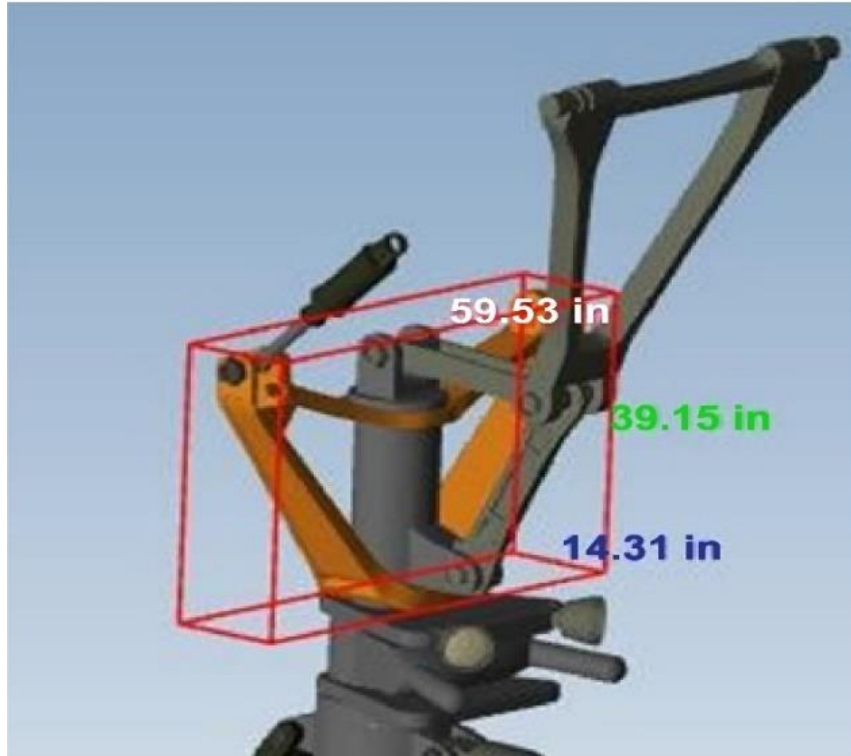

Figure 4-23 - Nose landing gear arm 06 (original)

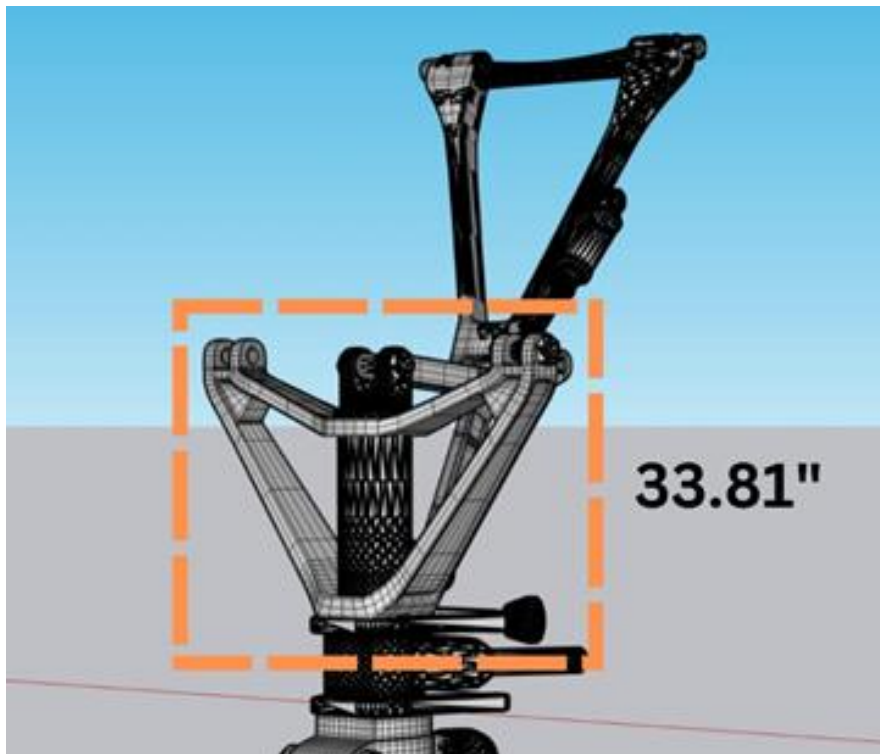

Figure 4-24 - Reduced nose landing gear arm 06

4.5 Warning Lights

A light that is designed to highlight towering buildings, high-rise structures, and any other things that could potentially interrupt air traffic is called an obstruction light. This type of light is also referred to as an aircraft warning light. Main goal is to construct a pair of obstruction lights like in the *Figure 4-26* (737 COMMERCIAL TRANSPORT, 2023).



Figure 4-25 Actual Obstruction lights

In order to create something equivalent, design of warning lights is created using Adobe Illustrator that was identical to the original as shown in the *Figure 4-26*.

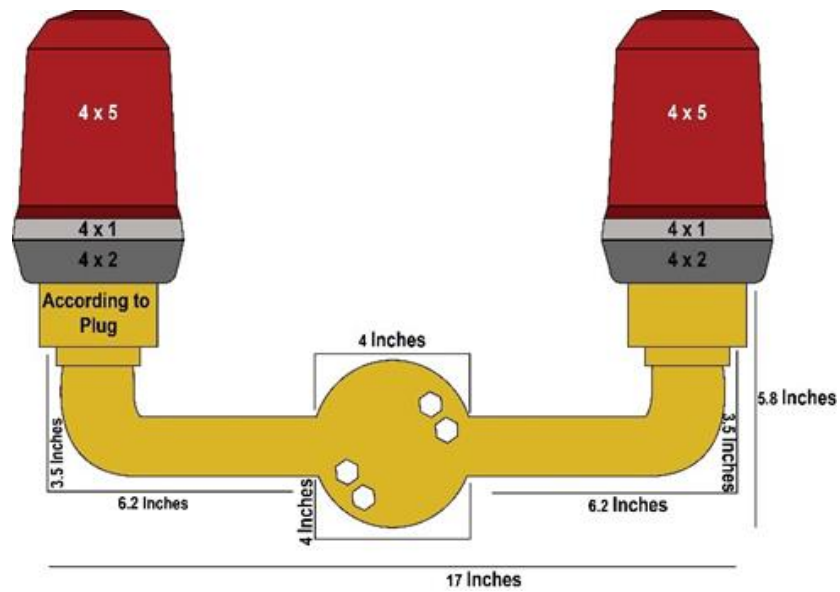

Figure 4-26 - Warning lights designed in illustrator

4.6 Logo

The first step in the process was to research different logos used by aircraft hangers and other related businesses. This research helped to identify common themes and design elements used in these logos. Based on this research, several concepts for the logo were developed. These concepts were then discussed and refined with a collaborative effort to ensure that they met the hanger's mission and values. Finally, with a collaborative decision it was decided to use the logo of IAS for the hanger to represent our department. The selected logo was then refined and final tweaks were made to ensure it met the requirement. The logo was then implemented in various materials such as signs, brochures, and websites. It was also used to create a consistent visual identity for the hanger.



Figure 4-27 - IAS-UMT Department logo

4.7 Hangar-Textured Wall

To commence with, hangar construction is consists of building it with the measurement of 144 inches (12 feet) height which also contains the obstruction light, to add on, the width of 192 inches (16 feet) which is divided into 60 inches (5 feet) of the door each and in between the space of 72 inches (6 feet) where the nose of Boeing 737-300 is exhibited and indicates that the aircraft is coming out towards the apron surface. Moreover, the height of the doors is 108 inches (9 feet) along with the cone hangar shape hut is two 36 inches (3 feet) estimated. To add up, the apron surface measurements is 192 inches (16 feet) in width and 108 inches (9 feet) of roadway as shown in fig 4-25.

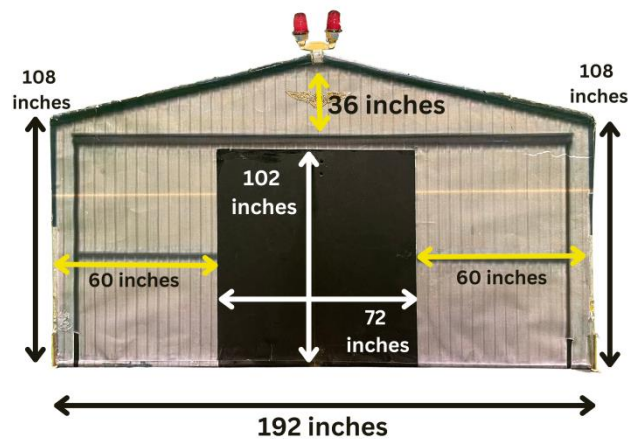

Figure 4-28 Hanger-Textured Wall

5 Fabrication

The assembly process began with the construction of the nose structure. The different parts were carefully fitted together, and any necessary adjustments were made to ensure a precise fit. The Nose landing gear was then attached to the nose. The paint was then applied to the mockup to make it aesthetically pleasing. Finally, all the measurements were cross-checked to obtain the final replica that was visually striking and true to the original design.

The infrastructure of our model combines, the nose of Boeing 737-300 aircraft, a hangar where the nose is resident, and the taxiway. To commence with, the Boeing 737-300 aircraft's nose measurement is 60 inches by 84 inches.

5.1 Nose

To commence with, the Boeing 737-300 aircraft's nose measurement is 60 inches (5 feet) by 84 inches (7 feet).

5.1.1 Rings

Boeing 737-300 nose was fabricated in fiber material. Initially, manufacturing was required to create a structure of the aircraft nose, so, the structure of the aircraft nose was created with an iron rod and MS iron pipes. The structure of the nose of the B737 300 mockup was made with MS Iron and made three rings in round shapes of different diameters. Front, middle, and backside rings of different diameters were made. The outer ring was made with Ms. Iron pipe-having length of 60 inches (5 feet) have been selected and the pipe was bent in a round shape with a bending machine. After this process, two pipes have an equal length of 60 inches (5 feet) attached to make an outside diameter. Middle diameter rings having a length of 48 inches (4 feet) were made with the same pipe material and the front ring having a 24 inches (2 feet) length by using equal pipe material and all ring pipes were bent with a bending machine. All pipes' joints were welded with a welding machine as in Fig 5-1.

5.1.2 Joining of rings

From the outer ring to the middle ring, took iron rods to have a horizontal length of 13.6 inches (1.13 feet) and a vertical length of 14.4 inches (1.2 feet). At first, iron rod blocks of different dimensions were attached to assemble the rings of the nose with the help of a welding machine. All blocks have an equal distance of 13.6 inches (1.13 feet) horizontally and 14.4 inches (1.2 feet) vertically. From the middle ring to the front ring, in this area rod's horizontal length was 11 inches (0.91 feet) of each rod, and the vertical length was 9.4 inches (0.78 feet). Each block is made with 11 inches (0.91 feet) length and 9.4 inches (0.78 feet) width until the distance from the middle to the front ring. All joints of the block frame are joined with an outer and front ring with welding machines as in the *Fig 5-1*.

5.1.3 Distance between outer and front ring

The total distance between the outer rings and to front ring is 84 inches (7 feet). The outer ring to middle ring distance was 41 inches (3.41 feet) and all distances were covered with block frames, which were made with iron rods and weld with a welding machine. Furthermore, the distance between the middle rings

to the front ring was 32 inches (2.66 feet) and covered with block frames and weld with welding machines.



Figure 5-1 - B737-300 Nose skeleton

5.1.4 Windshield

The frame of the windows is assembled with iron rods. Left and right side windows have equal sizes and angles and both front windows have equal sizes and angles. For the process of window one, again four-iron rods are used for this process. The side 1 rod has a length of 9 inches (0.75 feet), side 2 rod has a length of 8 inches (0.66 feet), side 4 rod has a length of 13 inches (1.08 feet), and side 3 rod has a length of 15 inches (1.25 feet). The right upper side joint joined at the angle of 110° and the lower joint of the lower right side joined at the angle of 55° . The left lower side joint joined at the angle of 100° and the left upper side joint joined at the angle of 95° . All joints of rods joined with the welding machine

For the process of window two, again four-iron rods are used for this process. The side 2 rod has a length of 13 inches (1.08 feet), side 1 rod has a length of 8 inches (0.66 feet), side 4 rod has a length of 10 inches (0.833 feet), and the side 3 rod has a length of 11 inches (0.91 feet). The right upper side joint joined at the angle of 126° and the lower joint of the lower right side joined at the angle of 72° . The left lower side joint joined at the angle of 88° and the left upper side joint joined at the angle of 74° . All joints of rods are joined with a welding machine.

For the process of window three, four-iron rods are used for this process. The side 2 rod has a length of 11 inches (0.91 feet), side 1 rod has a length of 12 inches (1 feet), side 4 rod has a length of 12 inches (1 feet), and the side 3 rod has a length of 17 inches (1.4 feet). The right side upper lever joint was joined at the angle of 110° and the lower joint of the lower right side was joined at the angle of 70°. The left lower side joint joined at the angle of 100° and the left upper side joint joined at the angle of 80°. All joints of rods joined with the welding machine and windshield frame was adjusted on ring structure frame. After this Plaster of Paris process was started.

5.1.5 Front Door

For the construction of door simply a texture of the cargo door was designed on the Plaster of Paris structure of the Boeing 737-300 aircraft mock-up accordingly to reduced length and width. The required length of the front door was 33 inches (2.75 feet) and the width is 16.8 inches (1.4 feet) which was followed in the designing of door.

5.1.6 Assembly of nose structure

After the formation of the aircraft skeleton, it is covered with a mate sheet from outside. In the next step, Plaster of Paris is applied on the mate 3 times and left for drying. In the further procedure, the nose structure of the B737 300 mock-up is shaped as per the requirement of the original B737 300 model.

Additionally, one of the important aspects of aircraft layout is the windshield. The windshield is constructed according to the required angles and measurements of each side of each window obtained through the scale down method. After that, the structure of the nose trimmed to get smoothness.

Furthermore, in the manufacturing process of nose structure the usage of fiber to get toughness in the outer layer. Fiber mixtures can be made by combining different types of fibers. The fibers can be natural or synthetic and can be blended in various proportions to create the desired result. The process of making a fiber mixture can vary depending on the specific fibers being used but generally involves mixing the fibers in a machine or by hand until they are evenly distributed. Different chemicals were used to obtain the mixture of FRP (Fiber reinforced polymer) like resin, cobalt, MKPDM, T20 Iron powder, White clay, marble powder, cesium powder, aerosol, and PVA powder.

All the mentioned chemicals were mixed to get the FRP mixture. Then this mixture was applied to Plaster of Paris three times. Then fiber mate was applied to the structure. The whole process is repeated four times to obtain the tough outer

layer and left to dry as in the *Fig 5-2*. After the nose structure is dried properly, in the next step outer layer is trimmed to get the shape of the nose according to the original B737 300. After getting the proper shape masterpiece of the aircraft nose is removed from the structure leaving the whole fiber structure of the nose of the B737 300 mock-up.

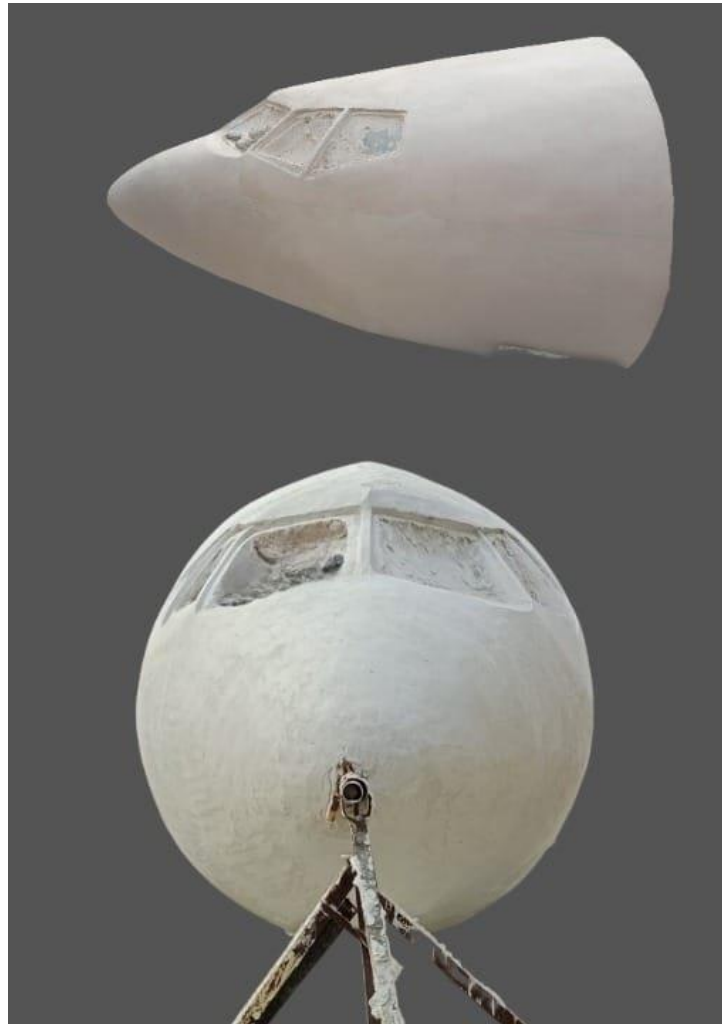

Figure 5-2 - Plaster of Paris structure B737-300

5.2 Assembling of Nose Landing gear

Assembling of Nose Landing Gear involve several steps. First of all different parts of landing gear were constructed from MS iron sheet of 2-3mm. All the parts were constructed separately and then joined using molding machine and required shape was given. All the parts are joined using electric rod by electric welding.

The axle is constructed by joining two iron pipes of 3 inches. Tubeless tires and rims which are commonly used for auto-car are joined to axel using bolts. Three readymade lights are bolted together to Nose Landing gear. One lights are then supported by clamp attached to landing gear arms from front and backside. Upper pipe attached to Nose Landing gear is detachable and was installed with the purpose of joining Nose Landing gear to aircraft.



Figure 5-3 Assembled Nose Landing gear Boeing 737-300

5.3 Riveting

Riveting is a common method used in the aerospace industry for attaching metal parts. Since fiber is used in the complete making of the model so riveting was not required in the joining of metal sheets but to make the model look more realistic and aesthetically good riveting is used. The design and implementation of riveting on a fiberglass replica of a B737 300 is a crucial step in creating a realistic and aesthetically pleasing replica. In the design process, the appropriate type and size of rivets were selected, as well as the layout and spacing of the rivets on the mock-up were marked. According to spacing riveted texture is provided.

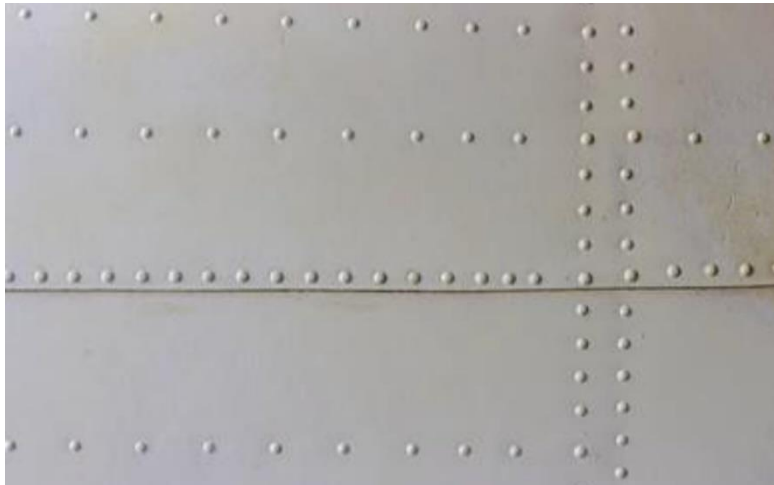

Figure 5-4 Riveting design of Boeing 737-300

5.4 Pitot tube

Took two 8mm MS iron sheet and grinded to reduce to 5mm and both sheet was attached to make nozzle of Pitot tube and 5mm MS sheet of plate was cut and both parts was welded and clips also attached. Welding rod J38.12 rod was used for making a joints of the Pitot tube.



Figure 5-5 Pitot Tube (Reduced)

5.5 Selection and application of Paint

5.5.1 Selection of color scheme

The selection of a color scheme for the mock-up was a crucial step in the project. The color scheme of the aircraft is an important aspect of its design and plays a significant role in its visual appeal. The research was conducted on the original aircraft to determine the correct colors and patterns to be used. After a

thorough analysis, it was decided to use [Picton Blue (45B1E8), Downriver (092256), Light Gray (D9D9D6), Dark Gray (A9A9A9)] for the mock-up as in *Figure 5-6*.

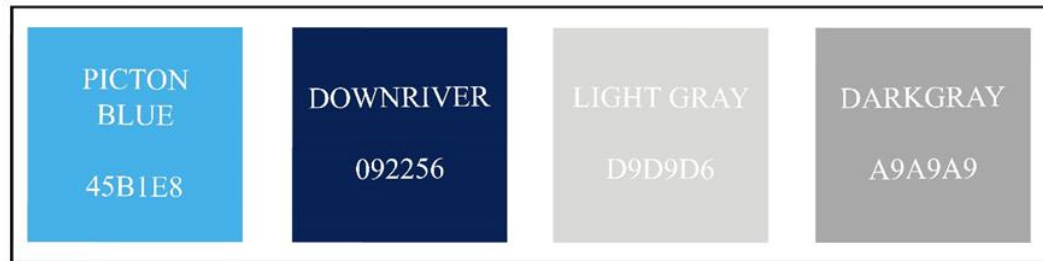

Figure 5-6 - Color scheme of B737-300 mockup

5.5.2 Application of Paint

Once the color scheme was selected, the next step was to apply the paint to the mock-up. The mock-up was carefully prepared for painting by cleaning and smoothing the surface. The paint was then applied in multiple layers to ensure a smooth and consistent finish. Care was taken to ensure that the colors and patterns were applied correctly and matched the planned aircraft.

5.6 Hanger-Textured Wall

Constructing a hanger is a complex process. In the making process of the hanger cement, sand, grit, bricks, and graving are used as material for the hanger wall. Furthermore, hanger wall is constructed of bricks and cement. At the same time, other materials will contribute to building the apron surface and finishing the steps of the hanger. An aluminum channel and metal float is used to give a corrugated texture to cement for the exterior of the hanger. The making process embraces a depth of 24 inches (2 feet) which supports the hanger wall and firm it handily.

5.7 Warning Light

The design of the replica was based on the original warning lights used in aircraft hangars. The replica was created to build using materials that closely matched the original lights, including iron, glass, and acrylic. Special attention was paid to the design of the lights, to ensure that the replica closely resembled the original lights. Two iron pipes was required, to bend them in a way that is identical to the design, and then connect them to both sides of the knob to successfully

build the appropriate pair of obstruction lights. To ensure that the design is precise. After that, two glass-holding bulbs will be constructed in the shape of obstacle lights and place them on top of iron poles. After that, a pair of obstruction lights was place inside the glass containers. To hang it on the wall, it was require to insert the iron rod of 17 inches (1.41 feet) long under the knob. In the final step, the entire body is painted glossy yellow, and the iron rod was painted by a glossy black paint. That helps to give it a more vivid appearance.

5.8 Logo

The IAS logo was decided to be used for the hanger logo. It was decided to use MS iron for making the logo. According to the size of the hanger, it was decided to take 30 inches (2.5 feet) piece of MS iron and create a design of the IAS department logo on it CNC laser cutting machine would be used to get the accurate design of the IAS department as in *Fig 4-28*.

5.9 Assembled Aircraft

The mock-up has a highly detailed exterior, with accurate markings and a paint scheme that closely matches the original Boeing 737-300. The replica has been built to a 1:2.5 scale. The replica has all the features of the nose of real aircraft, including the cockpit, and landing gear. The replica has a realistic look and feels that captures the essence of the original aircraft.

Overall, the final look of the assembled mock-up of the Boeing 737-300 is highly detailed and accurate. The mock-up closely resembles the original aircraft in terms of its appearance. The replica is a true representation of the original aircraft and will be a valuable addition to any collection. The replica will be a visual treat for aviation enthusiasts and will be used for educational purposes in the future.



Figure 5-7 Physical 3D model of Project Plan

6 Conclusion

Although there have been so many prototypes and mock-ups of aircraft's interior and exterior has been created around the world even some mockup where Aircraft Nose is attached with wall. However this kind of mock-up where half aircraft up till front door is visible out of Hanger textured wall is being first time constructed in the world. Half Nose out of hanger gives realistic look and adds logic to the mockup. It took much work to create this mock-up in Pakistan, especially where no proper resources are available to manufacture a prototype that can closely imitate the original model. A mockup of the B737-300 airliner's nose was constructed keeping in view the accuracy of layout and design.. During the assembly process, several challenges were encountered. One of the main challenges was ensuring that the different parts fit together correctly. This was overcome by carefully following the instructions and making any necessary adjustments.

This model can be a driving source for the youth to take part in such activities to help in research and development and innovative designs for aircraft manufacturing firms in Pakistan. For students like us having management background and knowledge, this model helped us to learn outside of our area of study. All the decision were made with collaborative approach during the selection of model, vendor and material. However, challenging, but at the same time, it was insightful in many aspects like; organizing resources at the cheapest cost, designing, assembling, and much more. Mock-up allowed understanding how all design decisions play together. Prototypes of aircraft made around the world have made this clear they are playing a vital role in making people aware of how aircraft look which none can easily access. This replica of Boeing 737-300 will also play a significant role in the learning and awareness of students, and it can be a source of attraction for visitors.

Such mockups could also help to make some improvements in layouts in the future and induce passion among students to display their talent in the practical side of aviation including any insights or lessons learned that could be applied to future projects.

7 Limitations

Following are the limitations of the replica made:

- I. There are no proper Aerospace workshops here in Pakistan for manufacturing aircraft mock-ups, so as per the availability of workshops in Pakistan all the manufacturing work was completed.

- II. The process of creating a mockup of 1:2.5 scale through manufacturing process was time-consuming and delayed the project timeline or impacted other resources.
- III. 3D modeling, related free course are not being offered elsewhere.
- IV. To construct the aircraft model mockup it was required to gain expertise.
- V. Creating a mockup of an aircraft was a complex and resource-intensive process, and various challenges were offered in obtaining the necessary materials, equipment, and expertise to build a mockup
- VI. There were many regulatory hurdles were placed in the way to navigate in order to build a mockup of an aircraft, such as obtaining the necessary permits to get original dimensions.
- VII. No access to real-world problems in the industry has limited our understanding of the practical applications of work.

8 Recommendations

- I. Workshops with enough tools and machines must be created specifically designed to work on aircraft mock-ups.
- II. Availability of workers or professionals should be ensured who would have worked on mock-ups of commercial aircraft or at least have expertise related to that.
- III. Building a library of reference materials and resources, such as blueprints and technical specifications, for the aircraft model being replicated.
- IV. Developing a set of guidelines and best practices for creating a realistic aircraft mockup.
- V. To support students with practical projects in aircraft design, the university should invest in state-of-the-art laboratory facilities and equipment to enable students to carry out their projects effectively.
- VI. An aero model should be made of any feasible material, which helps in knowing challenges that may be faced before the fabrication.
- VII. Students should be encouraged to show some interest in the technical side of aviation. They should be guided to work on the failed parts of the aircrafts.

- VIII. The aviation industry should sponsor such projects to make aircraft mockups up to the standards and close to reality.
- IX. Arranging workshops and training sessions on the latest technologies and techniques in aircraft design will help students stay up-to-date and develop their skills.
- X. Establishing partnerships with aviation companies will provide students of Aviation Management with hands-on experience and exposure to real-world problems to enhance their learning on how to manage aircraft designs and maintenance.
- XI. Allocating dedicated space for students to carry out their projects will provide them with a suitable environment to work in and improve the quality of their results.

9 References

- Brightman, M. (2018). In *The SketchUp workflow for architecture modeling buildings, visualizing design, and creating construction documents with SketchUp Pro and LayOut*. Wiley.
- Lockheed Polaris [mfr via RJF]. (2015). Retrieved from Flickr: <https://www.flickr.com/photos/sdasmarchives/20441570186/in/photostream/>
- CR929 Mockup Unveiled at Airshow China 2018. (2018). Retrieved from Aviation International News: <https://www.ainonline.com/aviation-news/air-transport/2018-11-06/cr929-mockup-unveiled-airshow-china-2018>
- 737 COMMERCIAL TRANSPORT. (2023). Retrieved 2023, from Boeing: <https://www.boeing.com/history/products/737-classic.page>
- Boeing Company. (2023, Jan 17). Retrieved from Encyclopædia Britannica: <https://www.britannica.com/topic/Boeing-Company>
- Pakistan Aeronautical Complex. (2023, Jan 16). Retrieved from Wikipedia: https://en.wikipedia.org/wiki/Pakistan_Aeronautical_Complex
- Probe: Pitot,Static. (2023). Retrieved from Boeing: <https://shop.boeing.com/aviation-supply/p/0856AE19AI=3F>
- Caggiano, A., Marzano, A., & Teti, R. (2016). Resource Efficient Configuration of an Aircraft Assembly Line. *Procedia CIRP*, 41, 236-241.
- Egorova, O., & Shcherbinin, D. (2016). Creating technical heritage object replicas in a virtual environment. *Frontiers of Mechanical Engineering*, 11, 108–115.
- Fabian. (2017). *How to Create Your First 3D Model in SketchUp: A Beginner-Friendly Introduction*. Retrieved from i.materialize: <https://i.materialise.com/blog/en/first-3d-model-in-sketchup-tutorial/>
- Funke, C. C. (1997). Concurrent Engineering in the Aircraft Industry and It's Relationship to the Development Process. *JSTOR*, 106, 359-369.
- HAYWARD, J. (2020). *The History Of The Boeing 737*. Retrieved from Simple Flying: <https://simpleflying.com/boeing-737/>
- Mas, F., Ríos, J., Gómez, A., & Hernández, J. C. (2016). Knowledge-based application to define aircraft final assembly lines at the industrialisation conceptual design phase. *International Journal of Computer Integrated Manufacturing*, 29(6), 677-691.
- Megson, T. H. (2018). *An Introduction to Aircraft Structural analysis*. Oxford: Butterworth-Heinemann, Elsevier.
- MRAZOVA, M. (2013). Advanced composite materials of the future in aerospace industry. *INCAS BULLETIN*, 5(3), 139-150.
- Smith, M., Hodges, D., & Cesnik, C. (2000). Evaluation of Computational Algorithms Suitable for Fluid-Structure Interactions. *Journal of Aircraft*, 37(2), 282-294.
- Tagliaferri, D., & Capsoni, C. (2016). *SNIR predictions for on-aircraft VLC systems*. Institute of Electrical and Electronics Engineers.
- TAYLOR, R. (1995). *Geotechnical centrifuge technology*. Blackie Academic & Professional.

Venkatesh , A., Xi , F. (., & Chung , J. (2021). Folding Methodology for Flexible Aircraft Interiors. *International Journal of Aviation, Aeronautics, and Aerospace*, 8(1).

Appendix A-Reference Drawings

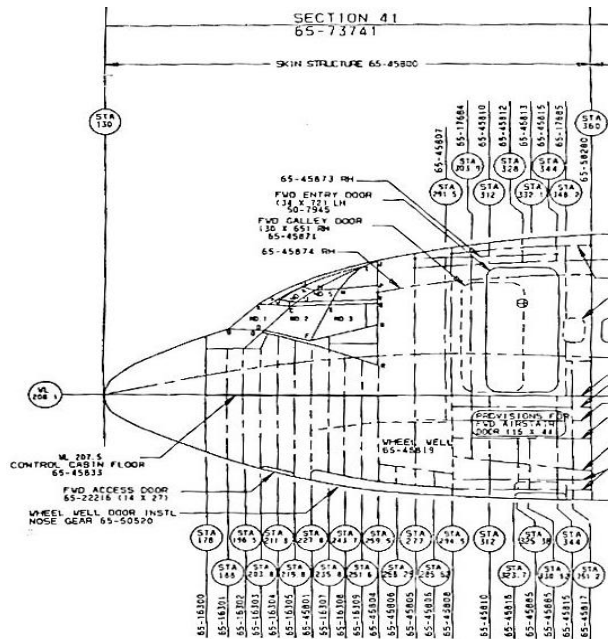

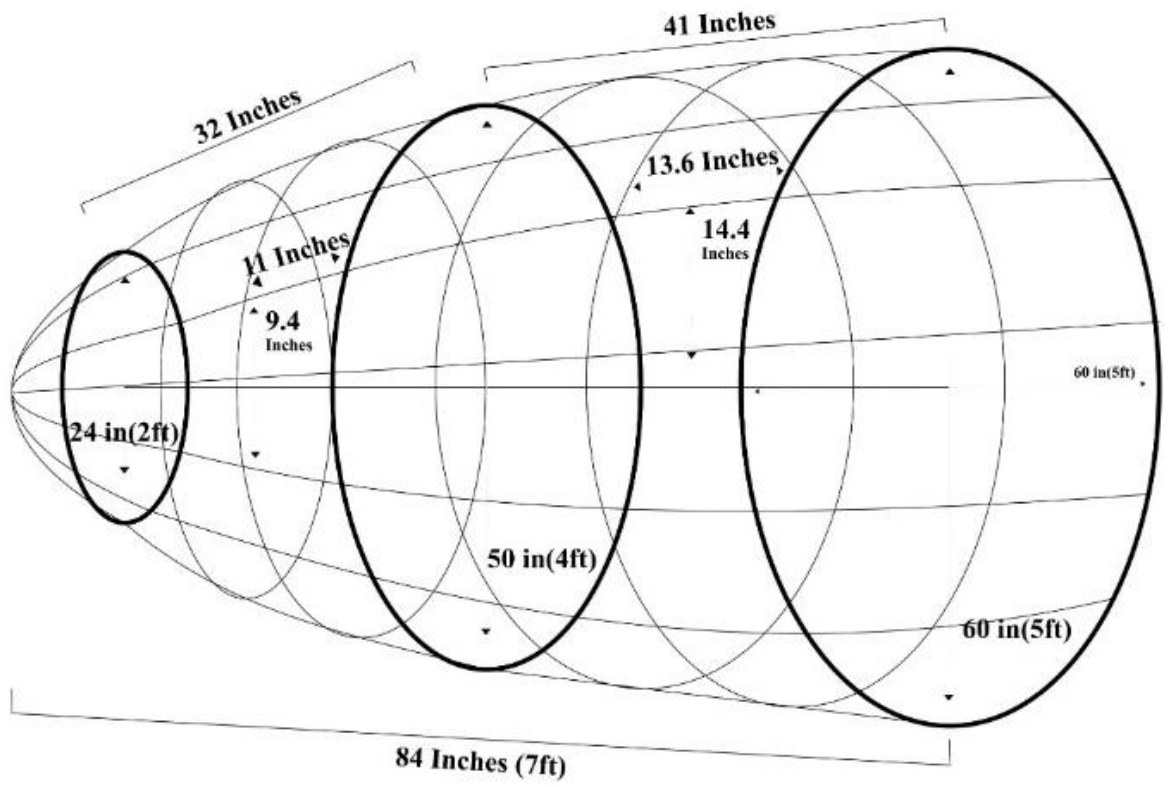

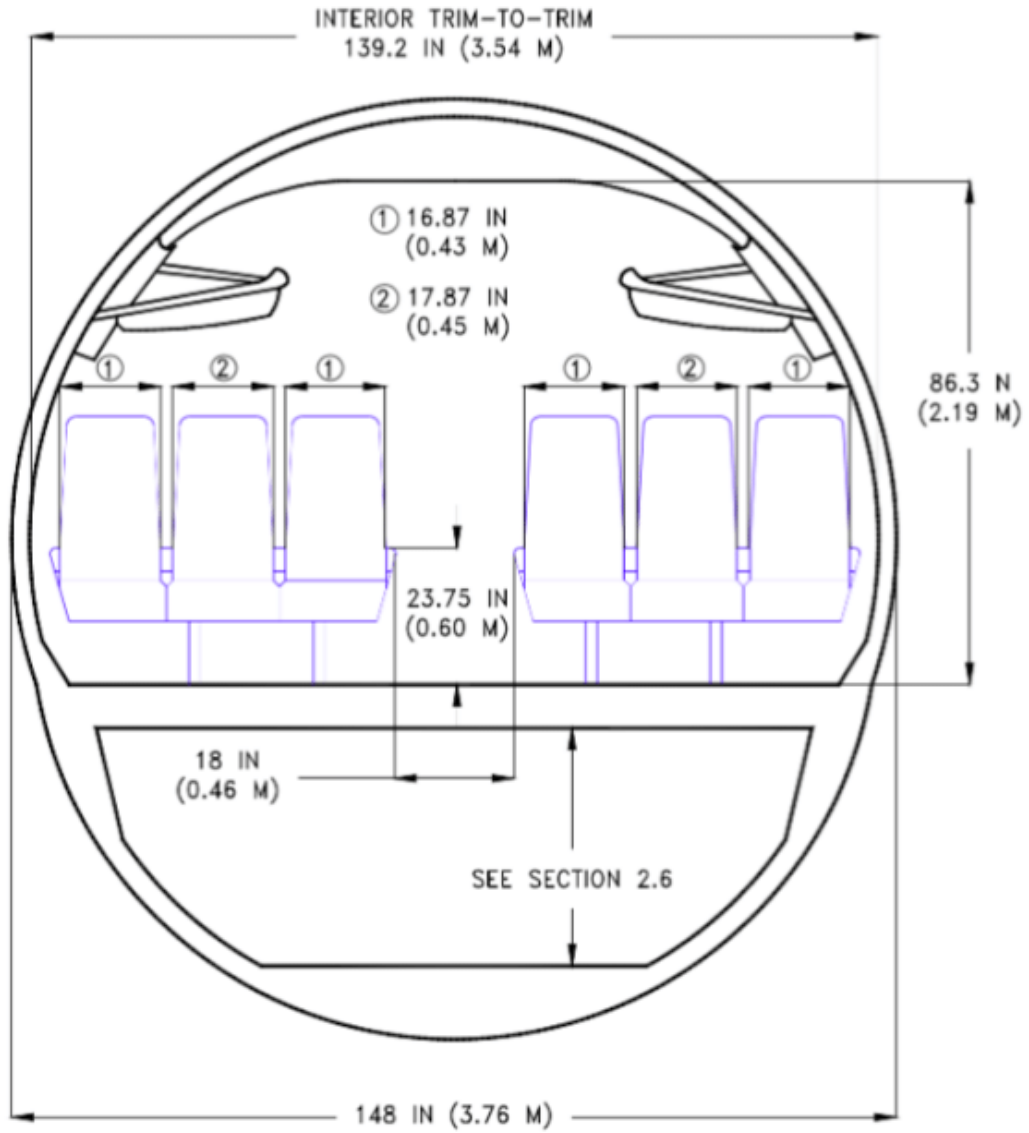

(Tagliaferri & Capsoni, 2016)