

FINAL PROJECT REPORT

Sensor Network for Remote Position Sensing



By

Hasnain Raza
Muhammad Umair
Muhammad Husham
Mubasher Hassan Bhatti

DEPARTMENT OF ELECTRICAL ENGINEERING
SCHOOL OF SCIENCE AND TECHNOLOGY
UNIVERSITY OF MANAGEMENT AND TECHNOLOGY

2010

Chapter 1

Introduction

1.1 Radio Frequency Identification System

Radio frequency identification is an enabling technology of smart object systems by ubiquitously tagging everyday object with a unique ID [1]. This is an advantage in terms of end-to-end objects managing and tracking, security, event status and environment monitoring, and interaction between reality and digital world [1].

It is a system in which short range radio frequency communication takes place between a moveable device and a host computer to exchange data. The moveable piece of equipment is called a 'transponder' and it holds some data within its non-volatile memory. The device that retrieves this data from transponder is called a 'transceiver'. It interrogates the transponder through an electromagnetic energy coupling process for data retrieval. Once the transceiver gets hold of data it passes on that data to a host computer. The computer makes sense of the data and saves it into a database table or links it to an artifact. A simplified diagram of RFID system is shown in figure 1.1.

A major advantage of a RFID system is its ability to carry data on a zero-power passive device. The data can be recovered in a non-contact and non-line-of-sight fashion using radio frequency communication [2]. It is the only technique that is practical in environmentally challenging conditions where other optical or contact based technologies would be useless [3]. Essentially an RFID is a portable database and a wireless extension of information systems.

1.2 Motivation

A problem that is faced in various manufacturing and service sector industries is the difficulty in tracking and identifying people and objects that are mobile in nature. Most of the time record keeping is done using various database management systems. But despite of this automation in place the initial data entry into a computer is by and large done manually. There is no smart way of automatically entering and updating data as soon as it is changed. While humans are excellent in performing intelligent work they are not very good at doing repetitive work without errors. As a result errors and defects in manual systems are usually traced back to initial incorrect data entry. Therefore there was a need for an automatic system that can track and identify items without getting in touch with them. This is only possible with a contact less technology that can work from a distance to retrieve data wirelessly while the things are on the move.

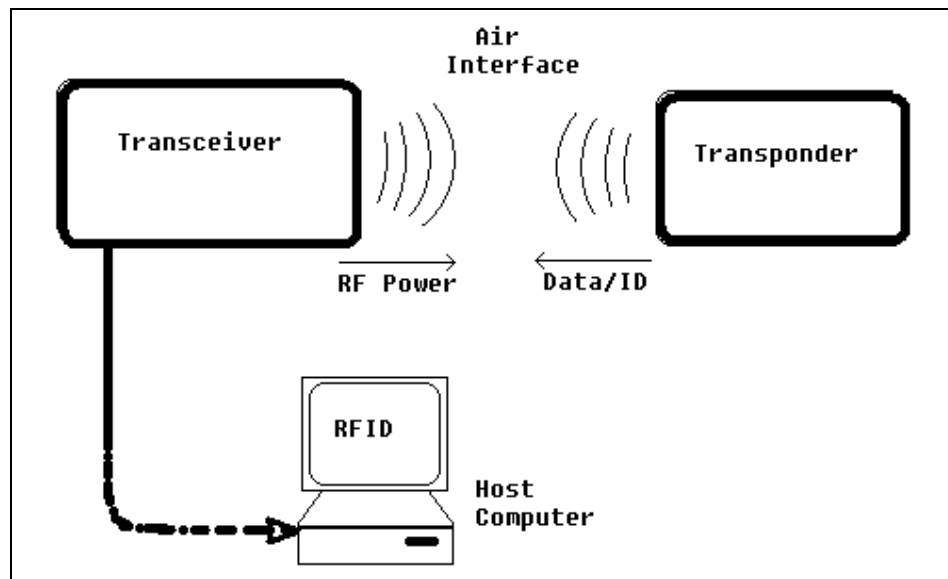

Figure 1.1 Simplified diagram of RFID system

RFID is the answer to this problem. It can solve this major problem of various industrial sectors where items or people have to be identified and their records have to be maintained on computer databases. By using

an RFID device the database entry would update automatically without any human intervention thereby reducing the chances of error.

1.3 Contact less Technology

With the advent of technological advancements in the area of integrated circuitry it has become possible to integrate data memory and processing logic onto a single silicon chip. The use of these small silicon microchips as transaction devices emerged as a form of an identification device which is known as the "smart card." A smart card device closely resembles a plastic credit card but possesses an embedded microchip. A microchip is an integrated circuit that can process and store data in memory. It resides on the front of the card between two layers of plastic. A technical committee of the International Organization for Standards (ISO) sets forth the dimensional and other device standards.

Contact less Card Standards cover a variety of types as embodied in ISO/IEC 10536 (Close coupled cards), ISO/IEC 14443 (Proximity cards), ISO/IEC 15963 (Vicinity cards). Non-contact class 1 smart cards are governed by ISO 10536 standard. In the experimental work of this thesis close-coupled cards were used as passive transponders.

1.4 Problem Definition

RFID systems have not received acceptance at consumer level on wide scale. One of its reasons is that they are expensive systems. They are designed with dedicated microchips (ASICs) or FPGAs which makes the design complex as well. There is a need for alternate designs which are simple and economical.

1.5 Solution Outline

In this thesis I propose a design of RFID system which is based on RISC (Reduced Instruction Set Computing) Microcontroller technology. This approach reduces the overall cost and complexity of the system. A

significance of this approach is that it functions effectively not only with RFID tags but also with smart cards at the same time.

There are two major challenges in the design of a combined RFID system; design of its data recovery system and design of demodulator system. A significant contribution of this thesis is that it proposes solutions to both of these challenging problems. For the first problem a firmware based Manchester Encoded DataStream Recovery algorithm is presented. For the second problem a RF close-coupling front-end hardware system is presented. These solutions are described in chapter 3 and chapter 4 respectively.

Chapter 2

Review of RFID Systems

2.1 Introduction

It was mentioned in chapter 1 that RFID systems provide an automatic means to identify physical objects without the need for line-of-sight communication. In this chapter I will give a review on RFID systems and their operating principles.

To understand about RFID systems let us first look at the various components of a RFID system.

2.2 Components of RFID system

An RFID system consists of following major components [3].

- Transceiver
- Transponder
- Antenna
- Channel
- Host Computer

2.2.1 Transceiver

It is a RF transmitter receiver module which is capable of generating and receiving radio frequency signals. It is connected to a RF antenna on one end and to a host computer on the other end. Essentially it bridges the gap between a portable transponder and a stationary host computer by receiving data from the former and passing that on to the later. A block diagram of transceiver circuit is shown in figure 2.1.

A transceiver is a key component of RFID system and performs multiple functions. The first function it performs is that of activating the

transponder circuit. This is because a RFID system is based on transfer of energy between two close-coupled resonant circuits. The microcontroller onboard the transceiver generates a digital signal at the required frequency, which is passed on to a current amplifier. The amplified current passes into the transceiver antenna, which resonates at the system frequency and creates a RF signal [5]. If a transponder is present within the RF field area, the transponder will energize and as a result it will transmit data back to the reader. It is the responsibility of the transceiver circuit to decode the incoming signal and finally send the decoded identification number to a host computer.

It can be observed from figure 2.1 that there are two major sections of the circuit namely analog section and digital section. The first section includes the antenna driver, amplitude-shift-keyed data demodulator, filters and gain blocks. The second section includes the decoder logic for Manchester DataStream and driver for host communication. In this thesis research work the first section is implemented on hardware. Its description, simulation results and circuit diagrams are discussed in chapter 4. The second section is implemented in firmware over a RISC microcontroller [7]. Its description, flow charts and C-language program are discussed in chapter 3

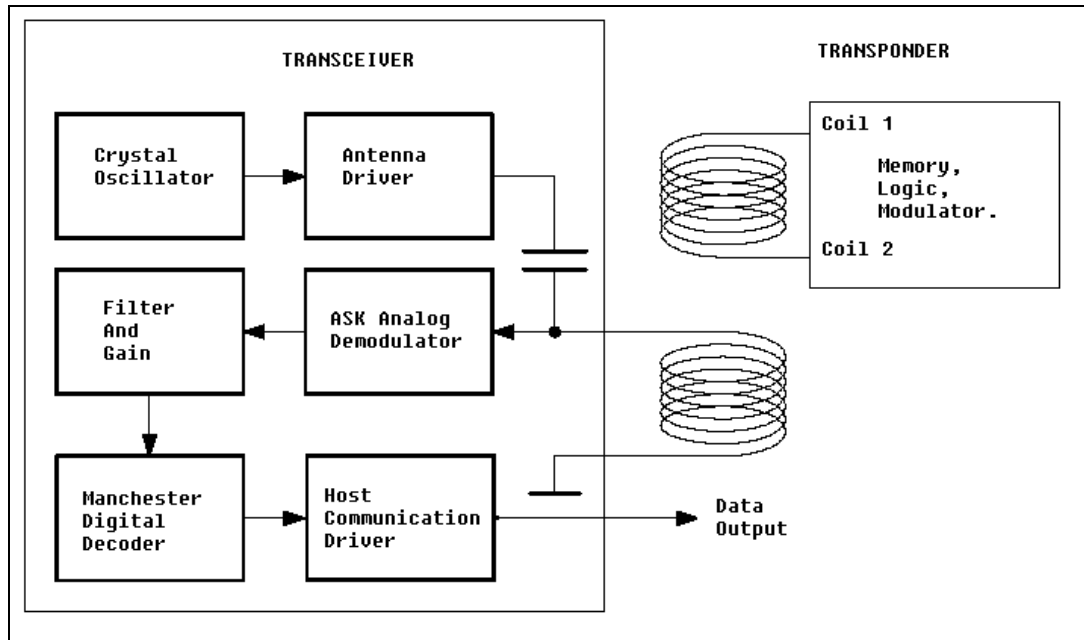

Figure 2.1 Block diagram of Transceiver circuit

2.2.2 Transponder

The mobile portion of RFID is called a transponder. It contains a resonant antenna, a low functionality microchip, and a limited amount of data storage capacity. This data storage is either permanent or rewritable. In a passive transponder in which there is no onboard power source on the transponder, the transceiver circuit provides the power to it. When the transponder circuit is powered up the transmission of data is activated that continues until it remains powered up. Figure 1.1 and figure 2.1 depict the interaction of transponder with a transceiver.

As already described above RFID transponders are made up of a low functionality microchip attached to an antenna. The transponder communicates via radio frequency (RF) with a transceiver. The transponder identification code may be read automatically without line of sight, through non-conducting material such as cardboard or paper, at a rate of several hundred reads per second and from a distance of several meters.

When a transponder is attached to an object, it typically stores information about the object. This information may range from static identification (serial number) to user written data (cost of the item). It may also be sensor data (temperature of a boiler). Transponders must both receive power and communicate within a narrow band of radio frequencies. Once the incoming RF field is detected, the microchip continuously transmits the identification code as long as the RF signal is applied.

Transponders can be classified into two types.

- Active Transponder
- Passive Transponder

2.2.2.1 Active Transponder

These types of transponders use onboard battery power for computation and for communication back to the transceiver module. Due to the availability of sufficient energy these can be read from a long-range distance of more than 100 feet. They are ideal for tracking items over long ranges, such as tracking shipping containers in transit. They have high power and battery requirements, so they are heavier and can be expensive.

2.2.2.2 Passive Transponder

These types of transponders use the energy in transceiver close-coupled reactive field as a power source for any on-chip computation and also for communication back to the transceiver. As the communication back to the transceiver is by means of the same signal that provides power to it so these transponders can only be read from a short-range distance of only few feet. These transponders are cheaper and hence can be applied in high quantities to individual items.

2.2.3 Antenna

An antenna enables a device to convert current and voltage to an electromagnetic wave. Both the transceiver and transponder are required to have an antenna of some form to enable communication. The operational frequency of the RFID system will determine the type of antenna, whether it be an electromagnetic resonant antenna or an electric dipole. Typically, the transmission frequency determines the type of antenna [6].

Close-coupled antennas in RFID systems perform dual functions. They transmit power as well as data. The RF signal that is generated by a transceiver is partly used by a transponder for energizing itself and at the same time it is used as carrier signal so that data is modulated over it. Figure 2.2 shows how the RF carrier signal is modulated by the transponder antenna signal to communicate data to the transceiver.

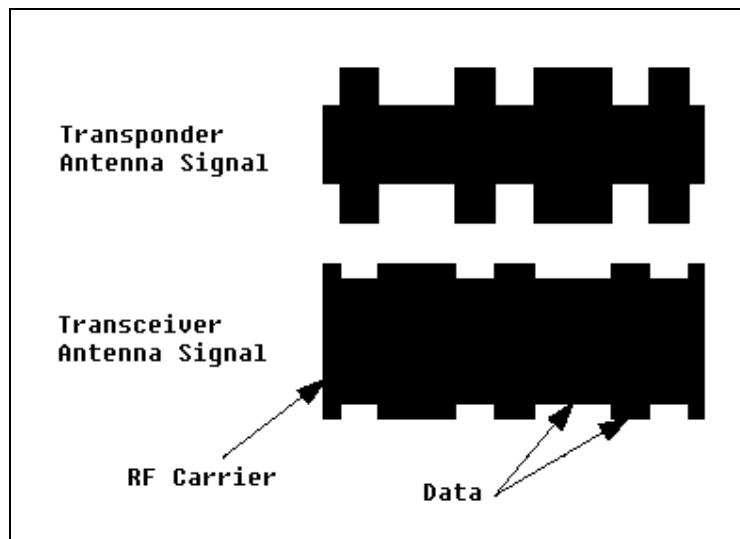

Figure 2.2 Signals on the two antennas

2.2.4 Channel

The medium over which the transponders and the transceiver communicate is called the channel. This channel is usually an air-interface

and we assume that the environment is uniform. In case where the channel is not truly free space but a noisy channel then the channel effects on the performance of RFID systems are very important. It affects the communication between the transponders and transceiver due to effects such as attenuation, multi-path, and interference from other transceivers and RF devices [4].

The physical objects to which the transponders are attached also affect the transponder's performance. Many common materials that the transponders are attached such as metal and water have considerable effects on the performance of the transponders. Changes in impedance bandwidth, detuning of the antennas, and reduction in the efficiency of the antenna are some of the factors that change the amount of power being delivered from the antenna to the transponder chip.

2.2.5 Host computer

The final stop for data in the RFID system is the host computer. Usually the interface of a transceiver with a host computer is a serialized shared bus link. Once the data reaches to this point the host computer makes sense of this data and saves it in an appropriate database table. This data can be later retrieved based on some query or search result.

The host computer can also determine what mode the transceiver operates in. For example, in an environment where transponders are passing near the antenna, the transceiver can be instructed to continuously look for transponders. If the transceiver antenna were to become portable, the host computer may instruct the transceiver to energize only at the users command.

2.3 RFID Applications

Once the initial process of item tracking and identification becomes automatic this will improve the performance of those organizations that