

Abstract

Automatic car parking is a MATLAB program which is used for automatic vehicle data entering such as number plate for identifying the car to be parked. First snapshot of the vehicle would be taken at entering gate, then system will detect the number plate from the whole picture and will extract the license number from the number plate .After extracting number it will send the number to the sever to enter in data base. Data base will contain the following entering , and number plate of car in database .At Exit side the same procedure will repeat like snapshot of vehicle, number plate extraction and send to the sever to update entry in database.

So our aim is to develop an effective automatic car parking for a specific and fixed no of cars for a company using image processing for using MATLAB.

Dedication

Throughout this project there have been a number of people who have helped to make it successful. We would like to thank the following:

- Muhammad Ali Murtaza (lecturer at UMT) for providing a basic concept of project. He has a constant source of guidance throughout the project and encourages us to do this project.
- And our friends who gave us a resources to do this project.
- And finally our parents for their financial support and help throughout the project.

Table of Content

Contents

1.1 Image Processing Using Matlab:	8
1.2 Serial Communication:	8
2.1 SPECIFICATION	9
2.2 CONSTRAINTS.....	9
2.3 Image Acquisition.....	10
2.4 SYSTEM DESIGN STEPS.....	10
2.5 Number Plate Detection	11
2.6 Why used fixed designs of number plate?.....	11
2.7 Detection of Green logo of computerized number plate	12
2.8 bwlabel.....	12
2.8.1 Syntax.....	12
2.8.2 Description	13
2.8.3 Why it used?	13
2.9 Regionprops	13
2.9.1 Syntax.....	13
2.9.2 Description	13
2.9.3 Properties.....	13
2.9.4 Why it used?	14
3.1 Template Matching.....	15
3.2 Correlation	16
3.2.1 Correlation formula	16
3.3 WORKING.....	16
4.1 Interlink Between PC and Hardware:.....	18
4.2 Interfacing camera with MATLAB	18
4.3 Components:.....	19
4.4 Faulty Circuit:	21

5.1 Image Acquisition.....	22
5.2 Number Plate Detection	22
5.3 Number Plate Extraction.....	22
References.....	23
Book,.....	23
A web page,	23
Software Based Codes	24
Number detection function	24
Character detection function.....	25
Correlation of numbers and alphabets function	26
Array 1.....	26
Array 2.....	30
Database function.....	34
Number Plate Detection Function (final).....	35
Hardware Based Codes	37
Serial Port Communication and Pic 16F877A controller.....	37
Introduction to Matlab	40
The MATLAB Working Environment	40
The MATLAB Desktop	40
Using the MATLAB Editor to Create M-Files.....	42
Getting Help	42
DIGITAL IMAGE PROCESSING.....	43
Fundamental Steps in Digital Image Processing:	43
Image Acquisition:.....	43
Image Enhancement:	43
Image Restoration:.....	44
Color Image Processing:.....	44
Wavelet and Multi resolution Processing:.....	44
Compression:	44
Segmentation:.....	44
Object Recognition:.....	44
Properties of light:	45

Representing Digital Images:	45
Resolution	45
Spatial Resolution	46
Gray level Resolution	46

List of Pictures

Figure 1: Block Diagram	8
Figure 3: Data Flow	9
Figure 4: Image Recognition	10
Figure 5: Different Number Plates	11
Figure 6: Yellow Number Plates	12
Figure 7: Color Detection	12
Figure 8: Gray Scale.....	14
Figure 9: Correlation flow	15
Figure 10: Correlation Formula.....	16
Figure 11: Number and Alphabets	17
Figure 12: Final Result.....	17
Figure 13: Camera Interface	19
Figure 14: Final Hardware	20
Figure 15: Faulty Circuit	21
Figure 2:Introduction of Matlab	41

Chapter 1: Introduction

The idea of the project was to design a software which enable a machine to detect the number plate of a random car and then tell the server that should that car be allowed to get parked or not. This would help in decreasing the man power and the machine will itself tell the car driver to park the car.

For this purpose we divided our project in two parts

- Image Processing Using MATLAB
- Serial Communication

1.1 Image Processing Using Matlab:

First step was to detect the number plate of a random car, convert it into grey scale, and then by using the method of correlation, extracting the numbers and alphabets from the plate.

1.2 Serial Communication:

Then the number extracted will be serially communicated to the micro controller and then the micro controller will help in operate the motor. The motor in this case will rotate clockwise and anticlockwise showing the movement of a parking hurdle moving up and down respectively.

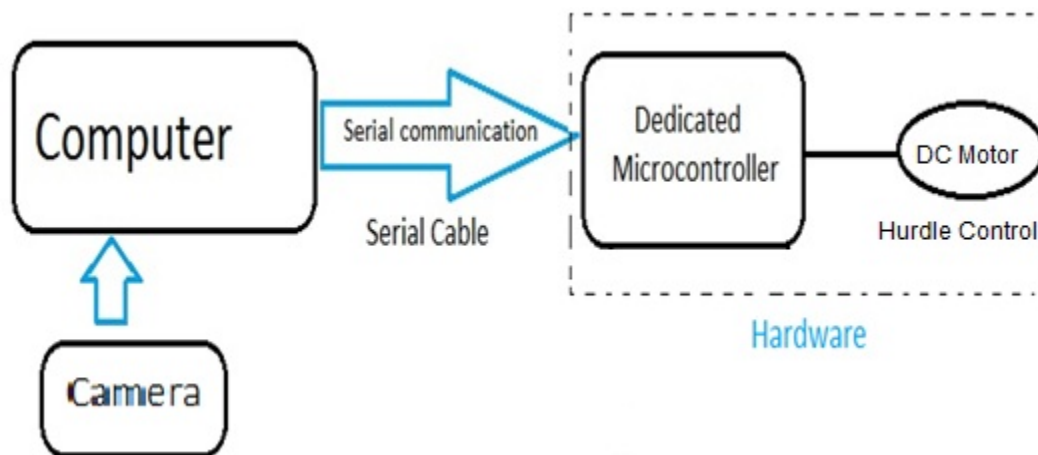

Figure 1: Block Diagram