

A Micro Computer-Based Methodology for Distance Protection on Long UHV Transmission Lines Using Symmetrical Components

Mashood Nasir
UMT, Lahore, Pakistan

Dr. Abdul Aziz Bhatti
UMT, Lahore, Pakistan

Abstract— This paper proposes a methodology for the long UHV transmission lines distance protection using microprocessor for fault detection, isolation and auto reclosing processes. In the present era, with the development of microprocessor technology, their extra efficient controlling and computing abilities can be utilized in distance relaying for efficient computing of fault distance and the type of fault occurred on the transmission line. Using Symmetrical component theory a single performance equation is developed that will encounter all type of faults on transmission lines regardless of the nature of the fault. Microprocessor will process on these sequence components to estimate the type of fault and the distance of fault from the relay. ETAP is used as a simulation tool to obtain the desired results. Although the formulation described here is independent of hardware yet it provides a complete analytical base for distance protection and is analyzed for different types of fault conditions using simulation tools.

Keywords- symmetrical components; distance protection; sequence circuits; faulty phase classification.

1. INTRODUCTION

In any electric power system, a protective relaying scheme is considered as the key element to ensure the reliability and continuous flow of power from the generating end to the user end. A protection scheme must protect electrical transmission lines and power generating equipments against the faults and consequent short circuits which may ultimately collapse the whole power system. Protective relays perform the function of monitoring of AC voltages and currents. These relays also locate and classify the faults and initiate the isolation by generating the tripping signal of circuit breakers. Microprocessor technology has efficient control and computational capabilities that can be utilized to implement distance relaying function with the intelligent fault diagnostic, sophisticated control and effective fault clearing features at a reasonable cost. Thus a protection scheme must apply a very pragmatic and pessimistic approach for clearing system faults. This paper proposes a digital scheme for long UHV transmission lines distance protection for fault detection, isolation and auto reclosing processes replacing the conventional analogue protection schemes. A microprocessor monitors the phasor values of currents and voltages at input and output side, samples and quantizes the input waveform to process with the digital values of pre fault and post fault currents and voltages values [2, 3, 5, 6]. Furthermore in a normal distance relaying system that uses phasor values of

voltage and current as input, six impedance calculating units are required for all ten types of shunt fault that may occur in transmission line but with the symmetrical component analysis tool these six impedance calculating units can be replaced by a single unit which will result in a considerable optimized and efficient protection system [2, 3].

With the use of symmetrical component theory a single performance equation is derived and implemented to encounter all types of faults. So a single impedance unit is used to calculate the location of the fault. Further this implementation also distinguishes between the faulty and healthy phases and the type of fault by employing the proposed algorithm. So overall this single performance equation based digital methodology is highly suitable for digital microprocessor applications to ensure the efficient and reliable protection of the transmission lines.

2. DATA SAMPLING AND FILTRATION TO OBTAIN PHASOR VALUES

Symmetrical components theory states that a poly phase supply of unbalanced phases can be resolved into symmetrical components and in case of three phase, these symmetrical components are given by

$$\begin{aligned} X_z &= \frac{1}{3} \{X_a + X_b + X_c\} \\ X_p &= \frac{1}{3} \{X_a + \alpha^2 X_b + \alpha X_c\} \\ X_n &= \frac{1}{3} \{X_a + \alpha X_b + \alpha^2 X_c\} \end{aligned} \quad (1)$$

Where X can either be a voltage or a current signal and X_z , X_p and X_n are zero, positive and negative sequence components respectively. The coefficients α and α^2 are $(-0.5 + j0.866)$ and $(-0.5 - j0.866)$ respectively.

Consider a sinusoidal input signal $x(t) = \sqrt{2} X \sin(\omega t + \phi)$ of frequency ω , whose phasor representation is $x' = X \exp^{j\phi} = X \cos \phi + jX \sin \phi$. Suppose that $x(t)$ is sampled at $t=kT$, $\{k=0, 1, 2, \dots\}$. Where, $x_k = x(kT)$ and $k = 0, 1, 2, \dots$. Its discrete Fourier is

$$X = \frac{2}{N} \sum_{k=0}^{N-1} x_k B_k \quad (2)$$

Where, $B_k = \exp\left(-j \frac{2\pi T}{T_0} k\right)$ and T_0 is the period of the fundamental frequency wave.

We will use the sampling rate of 600 Hz due to the advantage of using 12 samples per cycle of the data window discussed in [2,3]. For N=6, half data cycle window, the equation (2) becomes,

$$X = \frac{1}{3} \sum_{k=0}^5 x_k \cdot \exp\left(-j \frac{k\pi}{6}\right) \quad (3)$$

After spanning (3) for half cycle data window, the new value is given in (4)

$$X_{(new)} = \frac{1}{3} \sum_{k=0}^5 x_{k+1} \cdot \exp\left(-j \frac{k\pi}{6}\right) \quad (4)$$

(5) Is determined using (1) and (4) that represents a recursive relation for three symmetrical components to process further in microcomputer applications as given in [3].

$$\begin{aligned} X_0^{l+1} &= X_0^l + \omega_{l+1} (\Delta x_{a,l+1} + \Delta x_{b,l+1} + \Delta x_{c,l+1}) \\ X_1^{l+1} &= X_1^l + (\omega_{l+1} \Delta x_{a,l+1} + \omega_{l-3} \Delta x_{b,l+1} + \omega_{l+5} \Delta x_{c,l+1}) \\ X_2^{l+1} &= X_2^l + (\omega_{l+1} \Delta x_{a,l+1} + \omega_{l+5} \Delta x_{b,l+1} + \omega_{l-3} \Delta x_{c,l+1}) \end{aligned} \quad (5)$$

Where X^{l+1} : recursive value of X^l and $\omega_l = \frac{1}{9} \exp(-j \frac{k\pi}{6})$

3. IMPROVED PERFORMANCE EQUATION FORMATION

The symmetrical components based method to calculate the exact fault distance was proposed by A.G. Phadke [2] that processes the both real and imaginary parts of sampled data simultaneously to calculate the fault distance. However the computational efficiency of this process can be significantly increased by processing real parts of sampled data from the both end of the transmission line for the fault distance [8]. Similarly the imaginary parts can also be processed to classify the type of fault and the faulty phases involved.

Consider the sample system shown in figure 1 consisting of a two generators, their equivalent sources V_G (Z_{zG} , Z_{pG} , Z_{nG}), V_H (Z_{zH} , Z_{pH} , Z_{nH}), two transmission lines with zero positive and negative sequence impedance (Z_z , Z_p , Z_n) and (Z_z' , Z_p' , Z_n') having a mutual zero sequence impedance Z_m , protected by the proposed relay. Suppose the protected system is affected by a fault at distance X from relay location. Their respective zero positive and negative sequence circuits are shown when seen from bus P and can be represented with these equations,

$$V_{zh} = V_z^{(P)} - XI_z^{(P)} Z_z - XI_z' Z_m - R_{zf} I_{zf} \quad (6)$$

$$V_{ph} = V_p^{(P)} - XI_p^{(P)} Z_p - R_{pf} I_{pf} \quad (7)$$

$$V_{nh} = V_n^{(P)} - XI_n^{(P)} Z_n - R_{nf} I_{nf} \quad (8)$$

Where $V_z, V_p, V_n, I_z, I_p, I_n$ and Z_z, Z_p, Z_n are zero, positive and negative sequence of voltage, current and impedances respectively. V_{zh}, V_{ph}, V_{nh} are the values of sequence voltages at the point of fault.

Superscript P: data seen from bus P
Superscript Q: data seen from bus Q

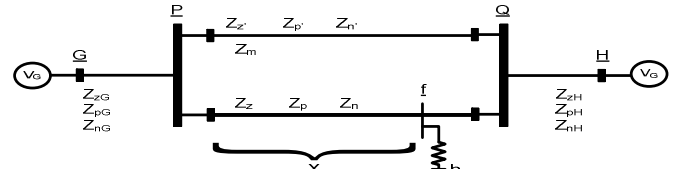

Figure 1: Sample System

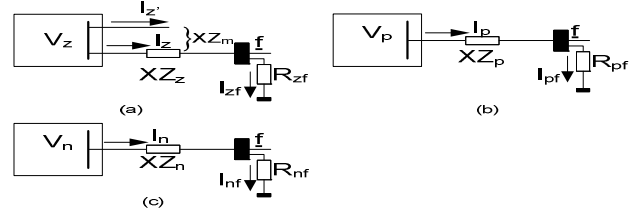

Figure 2: (a) zero sequence circuit (b) positive sequence circuit (c) negative sequence circuit

Since the only change is in positive sequence current after the fault has occurred, so total change in sequence circuits' current after the fault is represented by

$$\Delta I_z^{(P)} = I_{z(post)}^{(P)} - I_{z(pre)}^{(P)} \approx I_{z(post)}^{(P)} \quad (9)$$

$$\Delta I_p^{(P)} = I_{p(post)}^{(P)} - I_{p(pre)}^{(P)} \quad (10)$$

$$\Delta I_n^{(P)} = I_{n(post)}^{(P)} - I_{n(pre)}^{(P)} \approx I_{n(post)}^{(P)} \quad (11)$$

Where the subscript (post) and (pre) are the values before and after the fault and Δ represents the change in the value before and after the fault.

The voltage drops in sequence circuits are represented by

$$\Delta V_z^{(P)} = \Delta I_z^{(P)} Z_z + \Delta I_z^{(P)} Z_m \quad (12)$$

$$\Delta V_p^{(P)} = \Delta I_p^{(P)} Z_p \quad (13)$$

$$\Delta V_n^{(P)} = \Delta I_n^{(P)} Z_n \quad (14)$$

$$V_{p(pre)} = I_{p(pre)}^{(P)} Z_p \quad (15)$$

Using (9) ~ (15) in (6) ~ (8) yields,

$$\begin{aligned} V_{zh} &= V_z^{(P)} - XI_{z(post)}^{(P)} Z_z - XI_z' Z_m - R_{zf} I_{zf} \\ &= V_z^{(P)} - X \left(I_{z(post)}^{(P)} Z_z - I_z' Z_m \right) - R_{zf} I_{zf} \\ &= V_z^{(P)} - X \Delta V_z^{(P)} - R_{zf} I_{zf} \end{aligned} \quad (16)$$

$$\begin{aligned} V_{ph} &= V_p^{(P)} - XI_{p(post)}^{(P)} Z_p - R_{pf} I_{pf} \\ &= V_p^{(P)} - X \left(\Delta I_p^{(P)} + I_{p(pre)}^{(P)} \right) Z_p - R_{pf} I_{pf} \\ &= V_p^{(P)} - X \left(\Delta V_p^{(P)} + V_{p(pre)}^{(P)} \right) - R_{pf} I_{pf} \end{aligned} \quad (17)$$

$$\begin{aligned} V_{nh} &= V_n^{(P)} - XI_{n(post)}^{(P)} Z_n - R_{nf} I_{nf} \\ &= V_n^{(P)} - X \Delta V_n^{(P)} - R_{nf} I_{nf} \end{aligned} \quad (18)$$

Similarly when seen from bus Q (16) ~ (18) become,

$$V_{zh} = V_z^{(Q)} - (1-X) \Delta V_z^{(Q)} - R_{zf} I_{zf} \quad (19)$$

$$V_{ph} = V_p^{(Q)} - (1-X) \left(\Delta V_p^{(Q)} + V_{p(pre)}^{(Q)} \right) - R_{pf} I_{pf} \quad (20)$$

$$V_{nh} = V_n^{(Q)} - (1-X) \Delta V_n^{(Q)} - R_{nf} I_{nf} \quad (21)$$

The approach adapted here to deal with different types of faults is that the data seen from bus P and Q side is compared

and fault voltages terms are cancelled by comparing and as a result we can get an expression for fault distance X. After checking and deriving each fault type individually, all the expressions for the fault distance are compacted together to form a single performance equation whose coefficients will be further utilized in fault classification algorithm.

3.1 THREE PHASE FAULT

Since all the phases are involved in a three phase fault, only positive sequence circuit exists.

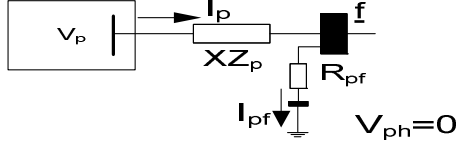

Figure 3: Symmetrical component representation of three phase fault

Boundary condition for this type of fault is $V_{ph}=0$ as shown in Figure 3

$$0 = V_p^{(P)} - X(\Delta V_p^{(P)} + V_{p(pre)}^{(P)}) - R_{pf} I_{pf} \quad (22)$$

$$0 = V_p^{(Q)} - (1-X)(\Delta V_p^{(Q)} + V_{p(pre)}^{(Q)}) - R_{pf} I_{pf} \quad (23)$$

Comparing (22) and (23) and solving for X while cancelling $R_{pf} I_{pf}$ terms yields,

$$X = \frac{(V_p^{(P)} - V_p^{(Q)}) + (\Delta V_p^{(Q)} + V_{p(pre)}^{(Q)})}{(\Delta V_p^{(P)} + V_{p(pre)}^{(P)}) + (\Delta V_p^{(Q)} + V_{p(pre)}^{(Q)})} \quad (24)$$

Since distance is a real variable so the ratio of the real terms will yield us the estimation of distance of fault X,

$$X = \frac{(V_p^{(P)} - V_p^{(Q)})}{(\Delta V_p^{(P)} + V_{p(pre)}^{(P)})} \quad (25)$$

3.2 Line To Line Fault

Since no ground is involved so zero sequence circuits will be absent in these types of faults. Only positive and negative sequence circuit exists and they are connected in parallel as shown in Figure 4.

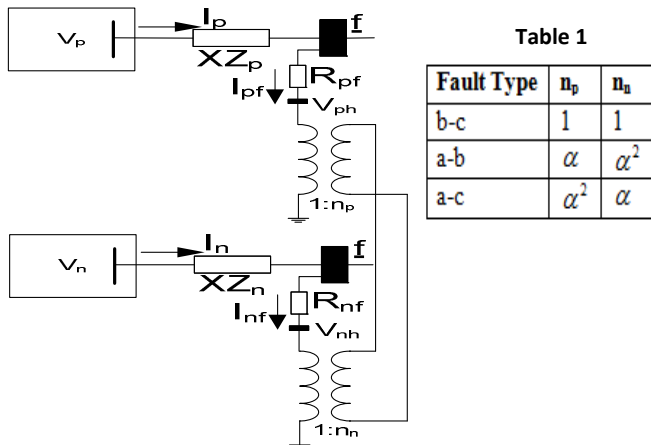

Figure 4: Symmetrical component representation of line to line fault

3.2.1 b – c fault

Since positive and negative sequence circuits are connected in parallel, so boundary conditions for b-c fault are

$$V_{ph} = V_{nh} \quad \text{and} \quad \Delta V_p = -\Delta V_n$$

Applying boundary conditions on data from bus P and Q yields,

$$V_p^{(P)} - X(\Delta V_p^{(P)} + V_{p(pre)}^{(P)}) - R_{pf} I_{pf} = V_n^{(P)} - X\Delta V_n^{(P)} - R_{nf} I_{nf} \quad (24)$$

$$V_p^{(Q)} - (1-X)(\Delta V_p^{(Q)} + V_{p(pre)}^{(Q)}) - R_{pf} I_{pf} = V_n^{(Q)} - (1-X)\Delta V_n^{(Q)} - R_{nf} I_{nf} \quad (25)$$

Comparing (24) and (25) and solving for X while cancelling

$$R_{pf} I_{pf} \quad \text{and} \quad R_{nf} I_{nf} \quad \text{terms yields,}$$

$$X = \frac{(V_p^{(P)} - V_p^{(Q)}) + (\Delta V_p^{(Q)} + V_{p(pre)}^{(Q)}) - (V_n^{(P)} - V_n^{(Q)} + \Delta V_n^{(Q)})}{(\Delta V_p^{(P)} + V_{p(pre)}^{(P)}) + (\Delta V_p^{(Q)} + V_{p(pre)}^{(Q)}) - (\Delta V_n^{(P)} + \Delta V_n^{(Q)})} \quad (26)$$

The ratio of the real terms will yield us the estimation of distance of fault X

$$X = \frac{(V_p^{(P)} - V_p^{(Q)}) - (V_n^{(P)} - V_n^{(Q)})}{(\Delta V_p^{(P)} + V_{p(pre)}^{(P)}) - \Delta V_n^{(P)}} \quad (27)$$

3.2.2 a-b fault

Positive and negative sequence circuits are connected in parallel. So by applying boundary conditions for a-b fault

$$X = \frac{(V_p^{(P)} - V_p^{(Q)}) + (\Delta V_p^{(Q)} + V_{p(pre)}^{(Q)}) - \alpha(V_n^{(P)} - V_n^{(Q)} + \Delta V_n^{(Q)})}{(\Delta V_p^{(P)} + V_{p(pre)}^{(P)}) + (\Delta V_p^{(Q)} + V_{p(pre)}^{(Q)}) - \alpha(\Delta V_n^{(P)} + \Delta V_n^{(Q)})} \quad (30)$$

Putting the value of $\alpha = -0.5 + j0.866$ collecting ratio of the real terms will yield us the estimation of distance of fault X,

$$X = \frac{(V_p^{(P)} - V_p^{(Q)}) + 0.5(V_n^{(P)} - V_n^{(Q)}) + 0.866\Delta V_p^{(Q)}}{(\Delta V_p^{(P)} + V_{p(pre)}^{(P)}) + 0.5\Delta V_n^{(P)} + 0.866\Delta V_n^{(Q)}} \quad (31)$$

3.2.3 a-c fault

Positive and negative sequence circuits are connected in parallel. So for boundary conditions

$$\alpha^2 V_{ph} = \alpha V_{nh} \quad \text{and} \quad \alpha^2 \Delta V_p = -\alpha \Delta V_n$$

$$X = \frac{\alpha[(V_p^{(P)} - V_p^{(Q)}) + (\Delta V_p^{(Q)} + V_{p(pre)}^{(Q)})] - (V_n^{(P)} - V_n^{(Q)} + \Delta V_n^{(Q)})}{\alpha[(\Delta V_p^{(P)} + V_{p(pre)}^{(P)}) + (\Delta V_p^{(Q)} + V_{p(pre)}^{(Q)})] - (\Delta V_n^{(P)} + \Delta V_n^{(Q)})} \quad (32)$$

Putting the value of $\alpha = -0.5 + j0.866$, collecting ratio of the real terms will yield us the estimation of distance of fault X,

$$X = \frac{0.5(V_p^{(P)} - V_p^{(Q)}) + 0.866(\Delta V_p^{(Q)} + V_{p(pre)}^{(Q)}) + (V_n^{(P)} - V_n^{(Q)})}{0.5(\Delta V_p^{(P)} + V_{p(pre)}^{(P)}) + 0.866(\Delta V_p^{(Q)} + V_{p(pre)}^{(Q)}) + \Delta V_n^{(P)}} \quad (33)$$

3.3. SINGLE LINE TO GROUND FAULT

In single line to ground fault, all zero, positive and negative sequence circuits exist and are connected in series.

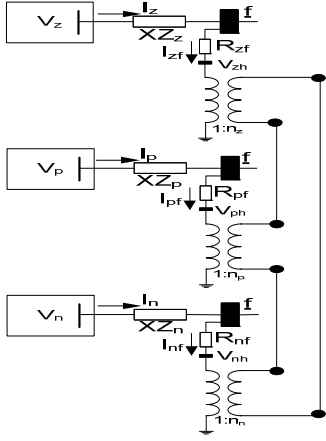

Table 2

Fault Type	n_z	n_p	n_n
a-g	1	1	1
b-g	1	α^2	α
c-g	1	α	α^2

Figure 5: Symmetrical component representation of line to ground fault

3.3.1 a-g fault

Boundary conditions for these types of faults are $V_{zh} + V_{ph} + V_{nh} = 0$ and $\Delta V_p = \Delta V_n$

Applying boundary conditions on data from bus P and Q yields,

$$0 = V_z^{(P)} - XI_{z(post)}^{(P)}Z_z - XI_{z,m}Z_m - R_{zf}I_{zf} + V_p^{(P)} - X(\Delta V_p^{(P)} + V_{p(pre)}^{(P)}) - R_{pf}I_{pf} + V_n^{(P)} - X\Delta V_n^{(P)} - R_{nf}I_{nf} \quad (34)$$

$$0 = V_z^{(Q)} - (1-X)\Delta V_z^{(Q)} - R_{zf}I_{zf} + V_p^{(Q)} - (1-X)(\Delta V_p^{(Q)} + V_{p(pre)}^{(Q)}) \quad (35)$$

$$- R_{pf}I_{pf} + V_n^{(Q)} - (1-X)\Delta V_n^{(Q)} - R_{nf}I_{nf}$$

Comparing (34) and (35) and solving for X while cancelling $R_{pf}I_{pf}$ and $R_{nf}I_{nf}$ terms yields,

$$X = \frac{(V_p^{(P)} - V_p^{(Q)}) + (\Delta V_p^{(Q)} + V_{p(pre)}^{(Q)}) + (V_n^{(P)} - V_n^{(Q)} + \Delta V_n^{(Q)}) + (V_z^{(P)} - V_z^{(Q)} + \Delta V_z^{(Q)})}{(\Delta V_p^{(P)} + V_{p(pre)}^{(P)}) + (\Delta V_p^{(Q)} + V_{p(pre)}^{(Q)}) - (\Delta V_n^{(P)} + \Delta V_n^{(Q)}) + (\Delta V_z^{(P)} + \Delta V_z^{(Q)})} \quad (36)$$

The ratio of the real terms will yield us the estimation of distance of fault X

$$X = \frac{(V_p^{(P)} - V_p^{(Q)}) + (V_n^{(P)} - V_n^{(Q)}) + (V_z^{(P)} - V_z^{(Q)})}{(\Delta V_p^{(P)} + V_{p(pre)}^{(P)}) + (\Delta V_n^{(P)} + \Delta V_z^{(P)})} \quad (37)$$

3.3.2 b-g fault

For b-g faults, we apply the boundary conditions $V_{zh} + \alpha^2 V_{ph} + \alpha V_{nh} = 0$ and $\alpha^2 \Delta V_p = \alpha \Delta V_n$ and fault distance can be determined as,

$$X = \frac{\alpha^2[(V_p^{(P)} - V_p^{(Q)}) + (\Delta V_p^{(Q)} + V_{p(pre)}^{(Q)})] + \alpha[(V_n^{(P)} - V_n^{(Q)} + \Delta V_n^{(Q)}) + (V_z^{(P)} - V_z^{(Q)} + \Delta V_z^{(Q)})]}{\alpha^2[(\Delta V_p^{(P)} + V_{p(pre)}^{(P)}) + (\Delta V_p^{(Q)} + V_{p(pre)}^{(Q)})] + \alpha[(\Delta V_n^{(P)} + \Delta V_n^{(Q)}) + (\Delta V_z^{(P)} + \Delta V_z^{(Q)})]} \quad (38)$$

Since distance is a real variable so the ratio of the real terms will yield us the estimation of distance of fault X. Putting the value of $\alpha = -0.5 + j0.866$, collecting ratio of the real terms will yield us the estimation of distance of fault X

$$X = \frac{0.5(V_p^{(P)} - V_p^{(Q)}) - 0.866(\Delta V_p^{(Q)} + V_{p(pre)}^{(Q)}) + 0.5(V_n^{(P)} - V_n^{(Q)}) + 0.866(\Delta V_n^{(Q)}) - (V_z^{(P)} - V_z^{(Q)})}{0.5(\Delta V_p^{(P)} + V_{p(pre)}^{(P)}) - 0.866(\Delta V_p^{(Q)} + V_{p(pre)}^{(Q)}) + 0.5\Delta V_n^{(P)} + 0.866\Delta V_n^{(Q)} - \Delta V_z^{(P)}} \quad (39)$$

3.3.3 c-g faults

The boundary conditions for this type of faults are $V_{zh} + \alpha V_{ph} + \alpha^2 V_{nh} = 0$ and $\alpha \Delta V_p = \alpha^2 \Delta V_n$.

Applying the boundary conditions on (16) ~ (18) for the data from P side and (19) ~ (21) for the data from Q side and comparing yields the fault distance X,

$$X = \frac{\alpha[(V_p^{(P)} - V_p^{(Q)}) + (\Delta V_p^{(Q)} + V_{p(pre)}^{(Q)})] + \alpha^2[(V_n^{(P)} - V_n^{(Q)} + \Delta V_n^{(Q)}) + (V_z^{(P)} - V_z^{(Q)} + \Delta V_z^{(Q)})]}{\alpha[(\Delta V_p^{(P)} + V_{p(pre)}^{(P)}) + (\Delta V_p^{(Q)} + V_{p(pre)}^{(Q)})] + \alpha^2[(\Delta V_n^{(P)} + \Delta V_n^{(Q)}) + (\Delta V_z^{(P)} + \Delta V_z^{(Q)})]} \quad (40)$$

Putting the value of $\alpha = -0.5 + j0.866$, collecting ratio of the real terms will yield us the estimation of distance of fault X.

$$X = \frac{0.5(V_p^{(P)} - V_p^{(Q)}) + 0.866(\Delta V_p^{(Q)} + V_{p(pre)}^{(Q)}) + 0.5(V_n^{(P)} - V_n^{(Q)}) - 0.866(\Delta V_n^{(Q)}) - (V_z^{(P)} - V_z^{(Q)})}{0.5(\Delta V_p^{(P)} + V_{p(pre)}^{(P)}) + 0.866(\Delta V_p^{(Q)} + V_{p(pre)}^{(Q)}) + 0.5\Delta V_n^{(P)} - 0.866\Delta V_n^{(Q)} - \Delta V_z^{(P)}} \quad (41)$$

3.6. SIMULATIONS AND RESULTS

The sample system shown in figure 7 is simulated on ETAP for a system of two buses and a transmission line of 100 miles. Fault is placed at 50 mile and a hypothetical bus is assumed at the point of fault. Short circuit analysis is made for half cycle fault and the desired value of voltages, currents and impedances from both the sides are taken from the text report of analysis for different types of faults. These values are used to calculate the symmetrical components of voltages, currents and impedances. Finally the proposed solution is used to calculate fault distance using these faults. Once the fault distance is available, proposed algorithm is used to classify the type of fault and the results are compared with theoretically known parameters to calculate the efficiency of the system. Fault distance and type, calculated by new algorithm for various types of faults, are summarized in the table 5.

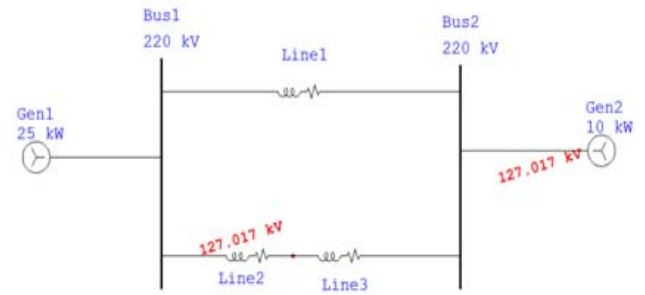

Figure 7: Simulation Circuit

Table 4: Calculation of a-g fault distance using equation (37)

Nominal kV=220 kV		Base kV=220 kV
Pre-fault Voltage=220 kV		
½ cycle fault at bus number 3		
Parameters	From Bus 1 (% of nominal)	From Bus 2(% of nominal)
"a" phase voltage, V_a	0.01	0.00
"b" phase voltage, V_b	100.00	100.00
"c" phase voltage, V_c	100.00	100.00
"a" phase current, I_a	0.001	0.00
$3I_0$	0.001	0.00
Positive sequence impedance Z_p	0.100E+04+j0.480E+05	0.155+E+04+j0.742E+05
Negative sequence impedance Z_{n1}	0.100E+04+j0.480E+05	0.155+E+04+j0.742E+05
Zero sequence impedance, Z_z	0.323E+04+j0.312E05	0.608E+03+j0.291E+05
Forecasted fault distance, X miles	49.55	
Theoretical fault distance, miles	50	
Percentage error, % ε	0.9	

Table 5: Forecasted fault distance for different fault types

Type of Fault	Forecasted Fault Distance(mile)
a-b-g	49.45
a-c	49.39
b-g	49.54
a-b-c	49.78

3.7. CONCLUSION

A symmetrical component based methodology for distance relaying and fault classification is described. The proposed method is specifically useful for its implementation on microprocessors. This improved methodology is preferred over previously proposed methodologies due to its simplicity and fault classification characteristics. Complex arithmetic divisions are eliminated and replaced by real arithmetic operations and newly proposed fault classification algorithm maximizes the efficiency of single pole autoreclosure procedure. Simulation results verify the accuracy and reliability of proposed methodology. So this improved and extended scheme is highly compatible with its implementation on microprocessors for fault location, identification and classification purposes to implement unattended, highly efficient and reliable distance protection.

REFERENCES

- [1] W. A. Lewis and S. Tippet, "Fundamental Basis for Distance Relaying on 3-phase Systems", in AIEE Trans., vol. 66, Feb. 1947, pp. 694-708.
- [2] A. G. Phadke, M. Ibrahim, T. Hlibka, "Fundamental Basis for Distance Relaying with Symmetrical Components", IEEE Trans. on PAS, vol. PAS-96, No. 2, pp. 635-646, March/April 1977.
- [3]. A. G. Phadke, T. Hlibka, M. Ibrahim, M. G. Adamiak, "A Microcomputer Based Symmetrical Component Distance Relay", in Proceedings of IEEE Power Industry Computer Applications Conf., pp. 47-55, 1979.
- [4]. D. L. Waikar, A. C. Liew, and S. Elangovan, "Design, Implementation and Performance Evaluation of a New Digital Distance Relaying Algorithm", IEEE Transactions on Power Systems, Vol. 11, No. 1, pp. 448-456, February 1996.
- [5]. D. L. Waikar, S. Elangovan, and A. Liew, "Further Enhancements in the Symmetrical Components Based Improved Fault Impedance Estimation Method part I: Mathematical Modeling", Electric Power Systems Research, vol. 40, pp. 189-194, 1997.
- [6]. D. L. Waikar, S. Elangovan, and A. Liew, "Further Enhancements in the Symmetrical Components Based Improved Fault Impedance Estimation Method Part II: Performance Evaluation", Electric Power Systems Research, vol. 40, pp. 189-194, 1997.
- [7] Rizk, A. M. Farouk, "Single-Phase Autoreclosure of Extra-High-Voltage Transmission Lines, An Investigation into the Residual Fault Current and Recovery Voltage", Proceedings of Institution of Electrical Engineers, vol. 116, pp. 96, 1969.
- [8]. Y. Liao, and S. Elangovan, "Improved Symmetrical Component-Based Fault Distance Estimation for Digital Distance Protection", IEEE Proceedings-Generation, Transmission and Distribution, vol. 145, no. 6, pp. 739-746, Nov 1998.