

University of Management and Technology, Lahore



**Dual Axis Solar Tracking System**

**Final Year Project**

**Submitted by:**

**Muhammad Asif Majeed-F2019019028**

**Muhammad Husnain-F2019019038**

**Supervised to:**

**Sir Waseem Iqbal**

**Department of Electrical Engineering**

**School of Engineering**

# **Dual Axis Solar Tracking System**

Submitted to the faculty of the Electrical Engineering Department of the University of Management and Technology Lahore In partial fulfillment of the requirements for the Degree of

Bachelor of Science

In

**Electrical Engineering**

  
19/12/2023  
Project Advisor

  
Co-Advisor

  
Director Undergraduate  
Studies

Department of electrical engineering

School of engineering

**University of management and technology Lahore**

# Similarity Report

University of Management and Technology, Lahore

## Similarity Report

Turnitin Originality Report  
Dual Axis Solar Tracking System by Muhammad Asif Majeed and Muhammad Husnain

From Reference Desk (LRC info desk)

- Processed on 05-Jul-2023 16:09 PKT
- ID: 2126764988
- Word Count: 14196

Similarity Index

10%

Similarity by Source

Internet Sources:

4%

Publications:

5%

Student Papers:

5%

Sources:

1. 1% match ()  
[Smith, Aalona. "Dual-Axis Solar Tracker". ScholarWorks@CWU, 2019](#)
2. 1% match (Goran Mijic. "Encyclopedia", Walter de Gruyter GmbH, 2018)  
[Goran Mijic. "Encyclopedia". Walter de Gruyter GmbH, 2018](#)

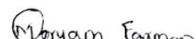
  
Checked by

  
Verified by CLO

**Note:**

- Sometimes the overall similarity index may be a smaller than the repository percentages combined. This would be due to overlapping text within the repositories.
- It is a system generated report.

## Declaration

### Declaration

I declare that the work contained in this thesis is my own, except where explicitly stated otherwise. In addition, this work has not been submitted to obtain another degree or professional qualification.

Singed: 

Date: 19-12-2023

## Acknowledgments

The authors would like to express their sincere appreciation to all those who provided us the possibility to complete this project. A special gratitude we give to our final year project advisor, Mr. Waseem Iqbal, who motivated us in choosing this project and helped us to coordinate our project.

Furthermore, we would also like to acknowledge with much gratitude the crucial role of Dr. Asif Hussain and Dr. Jawwad Chattha in guiding us about managing our project. Finally yet importantly, we are obliged to our faculty members Mr. Awais Saeed, Mr. Abdullah Khalid. We are appreciative to their comments and advices.

**Dedicated to our respected Teachers and  
Our parents for all their support and encouragement**

## Table of Contents

<b>Similarity Report</b>	iii
<b>Declaration</b>	iv
<b>Acknowledgments</b>	v
<b>List of figures</b>	x
<b>Abbreviations</b>	xi
<b>Abstract</b>	xii
<b>Chapter 1</b>	1
<b>Introduction of Dual Axis Solar Tracking System</b>	1
1.1 Introduction	1
1.2 Background	2
1.3 Working principle	4
<b>Chapter 2</b>	7
<b>Motivations, Related Literature and Problem Statement</b>	7
2.1 Motivations	7
2.2 Problem Statement	8
2.3 Literature Review	8
2.3.1 Monocrystalline silicon	9
2.3.2 Inclined shaft installation	12
2.4 Design Requirements	14
2.5 Engineering Merit	15
2.6 Success Criteria	16
2.7 Scope of Efforts	16
2.8 Benchmark	16
2.9 Project Success	17
2.10 Effect of light intensity	17
2.11 The efficiency of solar panel	17
2.12 Problem definition	18
<b>Chapter 3</b>	20
<b>Proposed Approach</b>	20
3.1 Proposed Approach	20
3.2 Development of solar system	21

3.3 Experimental setup	22
3.4 Electrical circuit design	23
3.5 Mechanical Circuit Design	24
3.6 Experimental procedure	25
3.7 Block diagram	27
Chapter 4	28
Hardware selection and brief hardware working Components:	28
4.2 Solar cell (200w)	28
4.2.1 Working principle	29
4.3 Arduino UNO	31
4.3.1 Working principle	31
4.3.2 Uses	32
4.4 Silicon (Si) LDR	34
4.4.1 Working principle of a Silicon LDR	34
4.5 IBT2 Motor driver	35
4.5.1 Working Principle:	35
4.6 L298 motor driver	36
4.6.1 Working principle	37
4.7 Potentiometer	38
4.7.1 Applications	38
4.8 12V dc gear motor	39
4.8.1 Key components	39
4.9 12V motorized hydraulic	41
4.10 Solar tracking system stand	41
4.10.1 Design and Construction:	41
Chapter 5	44
Implementation and/or Experimentation	44
5.1 Hardware implementation	44
5.2 LDRs configuration with Arduino UNO	45
5.2.1 Connection to Arduino UNO:	45
5.3 Arduino UNO connections with drivers	46
5.3.1 Identify the motor driver:	46
5.4 Drivers connection with motor and hydraulic	47

5.4.1 IBT2 Motor Driver with 12V DC Gear Motor:-----	48
5.5 Software implementation-----	49
5.6 Experimentation-----	50
Chapter 6-----	53
Conclusions and Future Directions-----	53
6.1 Conclusions and Future Directions-----	53
References:-----	55
Appendix:-----	56

## List of Figures

Figure 1.1 Working principle of dual axis solar tracking system.....	5
Figure2.1 Monocrystalline silicon, Polycrystalline silicon.....	9
Figure 3.1 Electric circuit design .....	24
Figure3.2 Mechanical design .....	25
Figure3.3 Block diagram.....	27
Figure4.1 Solar panel .....	29
Figure4.2 Working principle of solar cell .....	30
Figure4.3 Arduino UNO.....	32
Figure4.4 Use in dual axis solar tracking system .....	33
Figure5.1 Voc of dual axis solar tracking system .....	50
Figure5.2 Isc of solar tracking system .....	50
Figure5.3 Non-tracking system Voc .....	51
Figure5.4 Isc of non-tracking system .....	51
Figure5.5 Terrace experiment with tracking.....	52

## Abbreviations

LDR	Light Dependent Resistor
PV	Photovoltaic
HSAT	Horizontal Single Axis Tracker
HTSAT	Horizontal Single Axis Tracker with Tilted Module
VSAT	Vertical Single Axis Tracker
TSAT	Tilted Single Axis Tracked
PSAT	Polar Aligned Single Axis Tracker
UV	Ultra Violet
IR	Infrared

## Abstract

By dynamically orienting solar panels towards the location of the sun during the day, the dual-axis solar tracking system is intended to maximize the energy generation efficiency of solar panels. Without using any copied material, this abstract gives a succinct explanation of the dual-axis solar tracking system.

Light sensors, such as LDRs or photodiodes, are used in the system to measure the intensity of the sunlight in two dimensions. A microcontroller, generally an Arduino Uno, processes the sensor data before controlling servo motors that move the solar panel in both the azimuth (horizontal) and elevation (vertical) axes.

By continuously adjusting the position of the solar panel based on the sensor readings, the system ensures that the panel is aligned perpendicular to the incoming sunlight, maximizing the captured solar energy. This dual-axis tracking capability allows for optimal solar panel orientation throughout the day, resulting in increased energy production compared to fixed-mounted systems.

The power output of the dual-axis solar tracking system is 158.4, while the non-tracking system has a power output of 30.94. This means that, in the same location and under similar conditions, the dual-axis tracking system generates approximately 5 times more power than the non-tracking system.

The project involves the design, integration, and calibration of the sensors, motors, and microcontroller. It also includes mechanical assembly and mounting of the solar panel and motors on a sturdy frame that enables movement in two axes. The system's performance is evaluated through testing and optimization to maximize energy output under varying light conditions.

The dual-axis solar tracking system offers significant advantages in increasing solar energy generation, improving overall system efficiency, and maximizing the return on investment for solar installations. Its abstract nature allows for easy integration into various solar panel configurations, making it adaptable to different sizes and types of solar projects.

## Chapter 1

# Introduction of Dual Axis Solar Tracking System

### 1.1 Introduction

Solar power has become a feasible option as the world seeks out sustainable and renewable energy sources. However, it is crucial to optimize the orientation of solar panels towards the sun in order to increase their effectiveness and energy output. A dual-axis solar tracking system that intelligently aligns solar panels with the sun's position throughout the day is the goal of this senior project. This project aims to improve solar panel efficiency and increase power generation capabilities by incorporating four Light Dependent Resistors (LDRs), a 12V DC gear motor for azimuth movement, a 12V motorized hydraulic system for vertical movement, two Arduino Uno microcontrollers, resistors, and a custom-built dual-axis solar panel stand.

Solar panels can track the sun's movement dynamically thanks to the suggested method, maximizing the quantity of sunlight they can catch at any one time. Dual-axis tracking, which includes both azimuth (horizontal) and elevation (vertical) adjustments, is used by the system to precisely position the solar panel to ensure that it receives the most sunlight possible. As a result of the solar panel's continual alignment with the sun, energy absorption is optimized, and the process of producing solar power is substantially more efficient overall.

The method uses four carefully placed LDRs on the solar panel stand to precisely determine the sun's position. Light-sensitive resistors, or LDRs, respond to variations in light intensity by exhibiting varying resistance.

The system can determine the direction from which the most sunlight is incident by monitoring the resistance values of the LDRs. Calculating the exact angles needed for azimuth and elevation modifications depends on this information.

A 12V DC gear motor is used to alter the solar panel's azimuth, which causes it to rotate horizontally. The dual-axis solar panel stand's horizontal axis is coupled to this motor. One of the Arduino Uno microcontrollers analyses the LDR values to process the information and determine the ideal azimuth angle. The

microprocessor creates control signals to modify the motor's speed and direction based on this computation, allowing the solar panel to precisely align itself with the sun's east-west motion.

A 12V motorized hydraulic mechanism makes it easier for the solar panel to move vertically while managing its tilt angle. The data from the LDRs are inputted to the second Arduino Uno microcontroller, which then analyses the information and determines the ideal tilt angle to maximize solar energy absorption. The hydraulic system's operation is then carefully controlled by the microprocessor, enabling exact adjustment of the solar panel's elevation.

The dual-axis solar tracking system is centrally controlled by both Arduino Uno microcontrollers. The LDRs provide them with analogue readings, which they then translate into digital values. The ideal angles for azimuth and elevation movements are then calculated using these digital data. Utilizing Pulse Width Modulation (PWM) signals, the Arduino Uno microcontrollers control the speed and direction of the DC gear motor and hydraulic system, ensuring smooth and efficient positioning of the solar panel.

The dual-axis solar panel stand, created especially for this project, offers the system strong structural support and stability. It includes the LDRs and motors and firmly supports the solar panel. The stand's ability to move precisely along both axes makes it possible to track the sun's location throughout the day with accuracy.

The goal of this senior project is to create a dual-axis solar tracking system that optimizes solar panel orientation for increased energy production. Accurate azimuth and elevation motions are made possible by the system's use of LDRs, Arduino Uno microcontrollers, motors, resistors, and a specially made solar panel platform. This allows the solar panel to face the sun continuously. By maximizing solar energy absorption, this continuous tracking raises the solar panel system's efficiency and overall power output. The project highlights the practical implementation of solar tracking systems and their significant contribution to efficient and sustainable utilization of solar energy.

## 1.2 Background

The rise of solar power generation has been fueled by the rising global need for sustainable energy sources. The popularity of solar panels, which use sunshine to

create electricity, can be attributed to their sustainability and cleanliness. The efficiency of solar panels must be increased, nevertheless, in order to fully utilize their potential. The use of a dual-axis solar tracking system is one technique to accomplish this. In order to ensure the best alignment with the sun's position, this final year project attempts to create a system that automatically adjusts the orientation of solar panels along both the azimuth and elevation axes. This section will give a thorough history on the reasons for using a dual-axis solar tracking system as well as its advantages.

Fixed solar panels produce less energy than ideal throughout the day because of their set tilt and orientation. The angle of incidence between the sun's rays and the solar panel surface changes as the sun moves across the sky. The solar panel can actively track the motion of the sun by using a dual-axis solar tracking device, ensuring that it is constantly perpendicular to the incident sunlight. Increased power generation is made possible by the dynamic tracking, which increases the quantity of solar energy that can be captured and transformed into electricity.

When compared to fixed solar panels, the use of a dual-axis solar tracking system offers a number of significant benefits. First off, it greatly increases energy output. The solar panel's tilt angle and azimuth location are continuously adjusted by the system to maximize sunshine exposure and increase energy generation. According to studies, compared to fixed installations, solar tracking systems can boost energy production by 20–40%.

Second, a dual-axis solar tracking system lengthens the solar panel's useful daily operation. Fixed panels are only designed to provide the most energy at specified times of the day when the sun is at its utmost angular position. A dual-axis system, on the other hand, can successfully capture sunlight from sunrise to sunset, allowing for a longer period of time when useful energy can be produced.

The device also lessens the effect of shadowing by tracking the sun's movement. Solar panels can perform much worse when they are in the shadow of neighboring structures like trees or buildings. A dual-axis tracking system can reduce the impacts of shadowing and maintain a higher level of energy generation throughout the day by adjusting the tilt and azimuth.

A dual-axis solar tracking system implementation necessitates careful consideration of numerous parameters. The mechanical stability of the system

must be taken into consideration in the design because the solar panel and related components will be in constant motion. Furthermore, accurate and real-time tracking of the sun's location must be ensured by the control algorithm and sensor integration.

For precisely determining where the sun is, it is essential to select the right sensors, like LDRs.

The system also relies on microcontrollers, such as the Arduino Uno, to process sensor data, generate control signals, and drive the motors responsible for adjusting the solar panel's orientation. Efficient algorithms and control strategies need to be developed to ensure smooth and accurate movement of the solar panel.

The development of a dual-axis solar tracking system presents an opportunity to significantly enhance the efficiency and power generation capabilities of solar panels. By actively adjusting the tilt angle and azimuth position to align with the sun's movement, a dual-axis system maximizes energy absorption and extends the productive operation of solar panels throughout the day.

### 1.3 Working principle

The dual-axis solar tracking system operates on the premise of dynamically altering the position of solar panels to line up with the position of the sun throughout the day. This project seeks to maximize solar panel efficiency by utilizing Light Dependent Resistors (LDRs), Arduino Uno microcontrollers, motors, and a specially made solar panel platform. This section will outline the system's step-by-step operation while highlighting each component's function and contribution to precise solar tracking.

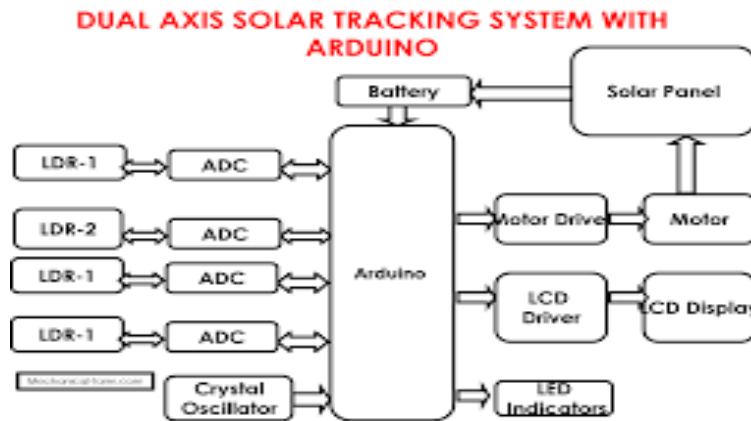

Figure 1.1 Working principle of dual axis solar tracking system

Four Light Dependent Resistors (LDRs) are strategically placed on the solar panel stand as the system's first component. Light-sensitive resistors, or LDRs, exhibit variable resistance depending on the amount of light that strikes them. The main sensors for determining the location of the sun are these LDRs. The LDR resistance values can be used by the system to calculate the direction of the greatest amount of sunshine.

The device uses a 12V DC gear motor attached to the azimuth axis of the dual-axis solar panel stand to rotate the solar panel horizontally. The resistance readings from the LDRs are processed by one of the Arduino Uno microcontrollers, which then determines the precise azimuth angle at which the solar panel should face the sun. This computation is used by the microprocessor to provide control signals that regulate the speed and direction of the DC motor, enabling the solar panel to move east to west in accordance with the sun's path.

An integrated 12V motorized hydraulic system allows for the vertical adjustment of the solar panel. The LDR readings are obtained by the second Arduino Uno microcontroller, which then analyses the information to determine the ideal tilt angle for maximum solar energy absorption. The microcontroller produces exact control signals to manage the hydraulic system, enabling precise adjustment of the elevation of the solar panel. By correcting for seasonal changes and maximizing energy absorption, this vertical movement makes sure that the solar panel always maintains an ideal angle in relation to the height of the sun.

The system is controlled by dual Arduino Uno microcontrollers. The LDRs' analogue readings are transferred to them, and they then digitize them. These digital data

are processed by the microcontrollers, which then determine the best azimuth and elevation angles. The microcontrollers direct the speed and direction of the DC gear motor and hydraulic system using Pulse Width Modulation (PWM) signals to ensure accurate and effective positioning of the solar panel.

The dual-axis solar panel stand that was specially made is essential to the system's operation. It incorporates the motors, LDRs, and other components and offers the solar panel the essential structural support and stability. The stand allows for smooth and accurate movement along both the azimuth and elevation axes, ensuring reliable tracking of the sun's position throughout the day.

The dual-axis solar tracking system's operating system makes use of LDRs, Arduino Uno microcontrollers, motors, and a specially made solar panel stand. The system determines the location of the sun by utilising the light detecting capabilities of LDRs. These details are processed by the microcontrollers, which then determine the best azimuth and elevation angles. The motors that power the solar panel stand are managed by the microcontrollers, allowing for precise and constant alignment of the solar panel with the sun's position. By ensuring maximum exposure to sunshine, this dynamic tracking increases the solar panel system's effectiveness and energy output.

## Chapter 2

### Motivations, Related Literature and Problem Statement

#### 2.1 Motivations

The idea was motivated by the social importance of solar energy, especially in light of the current global energy crisis. As a renewable energy source, solar panels offer enormous potential that must be realised. Therefore, there is an urgent need for strategies that can maximise solar energy harvesting. One such technique is the use of solar tracking systems, which have grown in popularity and usage over the past ten years, leading to the development of numerous types of tracking systems.

The fact that a former student at CWU (Central Washington University) finished a solar tracker in the past draws attention to the fact that there has already been work and research done in this area. The goal of this project is to design and produce a fully functional, dual-axes, active solar tracker that outperforms the capabilities of its predecessor. It builds on the framework established by the previous model.

The project intends to increase the efficiency and effectiveness of solar energy collecting by creating a better solar tracking system. Solar panels may follow the path of the sun using solar tracking systems, maximising their exposure to sunlight all day long. The solar panels' overall capacity for generating electricity is increased by their ability to track the sun.

The focus of the research is on a dual-axes, active solar tracker, which points to a more sophisticated and high-tech system. Dual-axes trackers enable exact alignment with the sun's location at any given time by allowing movement in two directions, both horizontally (azimuth) and vertically (elevation). The movement of active trackers is often facilitated by motors or actuators, ensuring precise tracking of the sun's path across the sky.

The project seeks to optimise solar energy collecting by creating a fully functional solar tracker with better capabilities. The energy output of solar panels can be greatly increased with the use of solar tracking systems, increasing their effectiveness and efficiency in converting sunshine into useful electricity. The ultimate objective of this initiative is to fully realise solar energy's potential as a renewable and sustainable energy source.

## 2.2 Problem Statement

A tool that can tilt a solar panel both vertically and horizontally in order to keep it perpendicular to the sun is necessary to maximise the electricity a solar panel produces. With the use of this flexible solar panel technology, the panel can follow the sun's path throughout the day to receive the most sunlight possible. The solar panel can produce more electricity than a conventional fixed panel since it is dynamically aligned with the position of the sun. The technology uses motors, sensors, and control systems to follow the sun's movement precisely and keep the gadget pointed in the direction that will best capture solar energy. This innovation raises the solar panel's overall effectiveness and output, making it a more efficient way to capture renewable energy.

## 2.3 Literature Review

The lack of conventional fuels and their negative effects on sustainable growth in today's society have motivated the hunt for alternative options to meet our increasing energy needs. Solar energy has emerged as a potential and environmentally benign choice among these options. Technology improvements have made it possible to use solar energy for a variety of purposes, such as the creation of heat energy, electricity, and fuel.

Solar cells, commonly referred to as photovoltaic cells, are essential for turning solar energy into electricity. Similar to the photoelectric effect, which occurs when light energy is absorbed and electrons are energised, the photovoltaic effect governs how these cells function. This process results in a voltage differential. Due to its effectiveness and affordability, crystalline silicon is the material that is most frequently utilised to create solar cells.

### 2.3.1 Monocrystalline silicon

Solar cell production frequently uses monocrystalline silicon, recognised for its high efficiency of roughly 15-20%. High temperatures, however, can impair its function and reduce its output efficiency by 10% to 15% of its initial value. However, although being less expensive, polycrystalline silicon has a similar band gap to monocrystalline silicon and is less effective. As a result, it is frequently utilised in inexpensive solar devices.

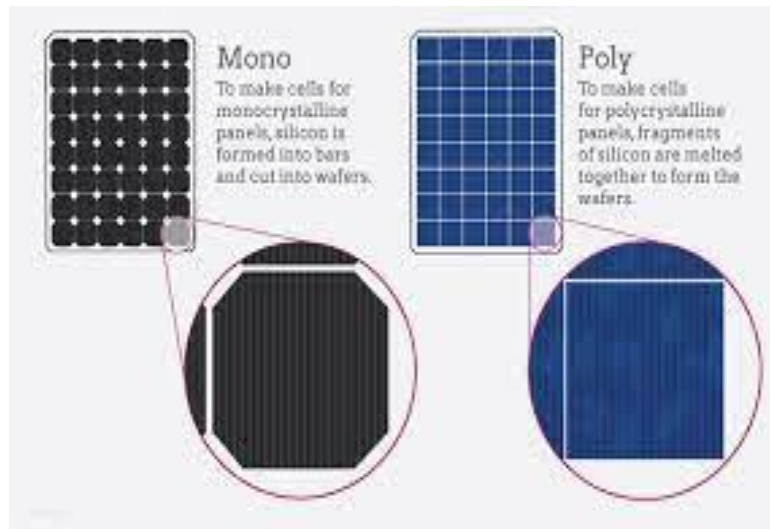

Figure2.1 Monocrystalline silicon, Polycrystalline silicon

Other materials, such as copper indium gallium (di) selenide (CIGS) and cadmium telluride (CdTe), are used to make solar cells in addition to silicon-based ones. These materials are used to create thin-film photovoltaic modules, which are solar cells. The cost of thin-film solar cells is lower than that of crystalline silicon cells. For instance, CIGS and CdTe thin-film cells are renowned for their versatility in use and cost-effectiveness. Another kind of thin-film solar cell that has the capacity to function effectively in high temperatures is the amorphous silicon cell.

The selection of materials for solar cells is influenced by various elements, including application-specific needs, cost, and efficiency. Despite the fact that crystalline silicon is still the most extensively utilised material because it is effective and inexpensive, the development of thin-film technologies using CdTe, CIGS, and amorphous silicon provides alternative options with specific advantages.

The depletion of conventional fuels and the need for sustainable development have driven the exploration of alternative energy sources. Solar energy, with its eco-

friendly nature, has gained significant attention. Solar cells, particularly those made from silicon, are key components in converting solar power into electricity. Crystalline silicon, including monocrystalline and polycrystalline forms, offers different efficiencies and costs. Thin-film photovoltaic modules, such as CdTe, CIGS, and amorphous silicon cells, provide additional choices for specific applications. The selection of solar cell materials depends on factors like efficiency, cost, and performance requirements, shaping the future of solar tracking systems and renewable energy utilization.

Cell Technology	Crystalline Silicon	Thin Film Silicon
Types	<ul style="list-style-type: none"> <li>• Mono-crystalline silicon (c-Si)</li> <li>• Poly-crystalline silicon (pc-Si/ mc-Si)</li> </ul>	<ul style="list-style-type: none"> <li>• Amorphous Silicon (a-Si)</li> <li>• Cadmium telluride (CdTe)</li> <li>• Copper indium gallium (di)selenide (CIG/CIGS)</li> </ul>
Temperature resistivity	Lower	Higher
Module Efficiency	13-19%	4-12%

Table 2.1: Types of Solar cell based upon the material

There are several other factors on which the efficiency of a solar cell depends.

- Temperature of cell
- Efficiency of energy conversion
- Tracking point of maximum power

Solar panels are made up of photovoltaic cells that are placed in an array to capture solar energy by using photons to excite the electrons in the material inside the cells. The location of the sun has an impact on how much light solar panels receive.

As a constant and plentiful source of radiation, the Sun produces free natural energy that can be used in place of non-renewable resources. In order to use this energy source for electrical purposes, solar panels are used. They are strategically positioned to collect maximum solar power. However, solar panels are limited in their ability to absorb solar power to certain hours of the day when the sunlight

directly falls on them at an orthogonal angle. The amount of solar energy that may be caught dramatically diminishes at other times of the day when the sun's beams are at a different angle.

Solar tracking systems were developed to get around these restrictions and make the most of the solar energy that is currently accessible. These devices are made to keep the sun's rays and the solar array at a perpendicular angle (90°). Three distinct modules are generally used in solar tracking systems.

Solar panel tracking systems are used to make sure that they are always perfectly aligned with the sun, enabling them to harvest more solar energy throughout the day. Solar tracking systems increase the effectiveness and energy production of solar power generation by continuously shifting the position of the solar panels to face the sun directly.

The sensor module, control module, and actuator module are the three modules that make up a solar tracking system. The sensor module measures the intensity of the sun or makes use of other tracking techniques to determine the sun's position. The control module analyses the sensor data and determines the changes that must be performed in order to keep the sensor at a perpendicular angle to the sun. The solar panel is then moved by the actuator module, which may include motors or other mechanical components, in response to commands from the control module to obtain the required alignment.

The effectiveness of solar panels in gathering solar energy throughout the day can be greatly increased by the use of solar tracking devices, which also dramatically increase the efficiency and energy output of solar panels. This technology plays a crucial role in optimizing the utilization of solar power and promoting the shift towards sustainable and renewable energy sources.

- The mechanism
- Driving motors
- The tracking controller

The device's solar tracking mechanism is in charge of precisely altering the placement of the solar panels to follow the path of the sun throughout the day. The

prototype of the device is made to be strong and resistant to adverse weather, ensuring its dependability and lifespan.

Single-axis trackers and dual-axis trackers are the two basic categories under which solar tracking devices fall. For small photovoltaic power plants or installations, single-axis tracking is a useful and economical alternative. It entails following the path of the sun along a single axis.

Single-axis tracking can be implemented using three different arrangements, each based on a different axis of tracking:

### 2.3.2 Inclined shaft installation

In this arrangement, the solar panels are mounted on an inclined shaft that allows them to rotate around a single axis, typically aligned with the east-west direction. The angle of inclination is adjusted to optimize the solar panels' exposure to sunlight throughout the day.

### 2.3.3 South-North axis horizontal installation

In this configuration, the solar panels are mounted on a horizontal shaft aligned in the south-north direction. The panels can rotate around this axis to follow the sun's east-west movement. This arrangement is particularly suitable for locations near the equator.

### 2.3.4 East-West axis horizontal installation

Here, the solar panels are mounted on a horizontal shaft aligned in the east-west direction. They rotate around this axis to track the sun's movement from sunrise to sunset. This arrangement is effective in maximizing the solar panels' exposure to sunlight throughout the day.

Each of these arrangements allows the solar panels to adjust their position and maintain an optimal perpendicular angle with the sun, maximizing the amount of solar energy captured.

### 2.3.5 Single-axis tracker

Solar power plants can increase their energy output compared to fixed solar panels by installing single-axis tracking devices. The tracking system makes sure that the panels are always facing the sun, which improves how well they can turn sunlight into power. Single-axis trackers offer a practical and affordable option for many

applications, whereas dual-axis trackers enable even more precision by changing the panels in both the horizontal and vertical planes.

A single cardinal direction is the only one the sun moves in with a single-axis tracker. It typically consists of a single row configuration for tracking. The methods mentioned earlier represent different arrangements in which a single-axis tracker can be implemented. Regardless of the specific arrangement, the working mechanism of these methods is similar. The angle between the sun and the surface of the solar collector is calculated and monitored. Based on this information, the collectors are adjusted to follow the movement of the sun, maximizing the capture of solar radiation. By employing this tracking mechanism, a higher percentage of solar energy can be harnessed, resulting in increased energy production.

Imposition of single axis tracking system including

- HASAT Horizontal Single Axis tracker
- HTSAT Horizontal Single Axis Tracker with Tilted Module
- VSAT Vertical Single Axis Tracker
- TSAT Tilted Single Axis Tracker
- PSAT Polar Aligned Single Axis Tracker

The rotating axes of a dual-axis tracker are parallel to one another. The fundamental axis is one of the axes that is fixed and always points in the same direction as the ground. The secondary axis, which is the other axis, has autonomous motion. The movement of the sun can be followed by dual-axis trackers in both the horizontal and vertical axes. With the use of this dual-axis movement, the sun can be precisely tracked throughout the day, maximising the solar panels' exposure to light and enhancing energy output. Dual-axis trackers, as opposed to fixed or single-axis tracking systems, are able to catch more solar radiation since they can continually modify the position of the solar panels. Below are some other uses for dual axis solar trackers.

- TTDAT Tip Tilt Dual axis Tracker
- AADAT Azimuthal altitude dual axis tracker

### 2.3.6 Tip Tilt Dual-Axis

By combining both tip and tilt movements, a Tip Tilt Dual-Axis Tracker improves solar tracking capabilities. This dynamic tracking strategy guarantees the solar panel's ideal alignment with the sun, enhancing the production of electricity from solar systems.

### 2.3.7 Azimuthal altitude dual-axis

In order to align solar panels with the sun's position for maximum energy absorption, an azimuthal altitude dual-axis tracker uses two axes, azimuth and altitude. While the altitude axis allows for vertical adjustment, managing the tilt angle, the azimuth axis provides horizontal rotation of the panel, monitoring the sun's east-west path. The tracker makes sure that the solar panel is always facing the sun in the best possible way throughout the day to maximise energy production. In comparison to fixed panels, this dual-axis design provides more accuracy and efficiency, which increases the solar system's overall energy generation.

## 2.4 Design Requirements

### Dual-Axis Solar Tracking System Design Requirements

To maximise energy capture, the dual-axis solar tracking system must precisely follow the sun's location throughout the day. It must also maintain the solar panel's precise alignment with the incoming sunlight.

The system's light sensors should be highly sensitive and responsive in order to precisely detect changes in sunshine intensity. They ought to be able to handle a range of lighting conditions and have a broad operating range.

The servo motors selected for the project should provide sufficient torque and speed to facilitate smooth and accurate movement of the solar panel in both the azimuth and elevation axes. They must be capable of handling the weight and size of the solar panel.

The system design should prioritize power efficiency to minimize energy consumption. This can be achieved through the use of low-power components, efficient motor control algorithms, and power management techniques.

The system should be designed to withstand outdoor conditions, including temperature fluctuations, humidity, and exposure to sunlight. It should incorporate robust and weather-resistant materials to ensure long-term reliability.

Safety considerations are crucial, and the design should include proper grounding, insulation, and protection against electrical hazards. Mechanical components should be securely mounted to prevent accidents during installation, operation, and maintenance.

The dual-axis solar tracking system should be compatible with various types and sizes of solar panels. It should be adaptable to integrate seamlessly with existing solar installations or allow for future expansions.

The system design should be scalable to accommodate larger solar arrays or additional panels. It should also be flexible enough to adapt to different geographical locations and site-specific requirements.

An efficient control algorithm is necessary to process sensor data, calculate precise tracking angles, and control the movement of the servo motors. The algorithm should be optimized for accuracy, responsiveness, and reliability.

The project should aim for a cost-effective design that balances system performance and affordability. This involves careful selection of components, minimizing installation complexity, and optimizing maintenance requirements.

## 2.5 Engineering Merit

Drawing from the knowledge and abilities gained via several courses in the MET programme at Central Washington University, this project spans a wide range of engineering ideas and concepts. Strength of materials, software coding, stress analysis, and possibly heat transmission are important areas of focus. By applying these principles, the project aims to design and construct a device that meets specific constraints, such as maintaining a perpendicular angle with direct sunlight, allowing for a wide range of rotation, and maximizing energy absorption. The strength of materials will be crucial in ensuring the device's structural integrity and longevity. Software coding will play a significant role in implementing control systems and automation for the device's movement and tracking capabilities. Stress analysis will be employed to evaluate and optimize the device's performance under varying conditions. Additionally, considerations may be made regarding heat

transfer to ensure the device operates efficiently and withstands temperature variations. Through the application of these engineering principles, the project aims to achieve a cost-effective, efficient, and durable solution.

## 2.6 Success Criteria

The achievement of full operational adjustments from both axes of the gadget is one of the project's success criteria. This means that the gadget must be able to provide an angle of declination of at least 45 degrees on the altitudinal axis and rotate 180 degrees on the azimuthal axis from any place. A perpendicular angle with direct sunlight must also be carefully maintained by the instrument, with a tolerance of 1-3%. These standards will be used as the barometers to gauge the project's success.

## 2.7 Scope of Efforts

The project will include four crucial parts that are necessary for it to function. The device's basis is the solar panel, which will be firmly installed and placed above the base to increase endurance and structural stability. For all the other parts of the gadget to be stable, the base component is essential. Two drivers, a stepper motor and a linear actuator, are positioned in between the base and the solar panel. Each driver will be in charge of managing either the vertical axis or the horizontal axis. These parts enable the gadget to move and adjust precisely in order to maintain the proper orientation with respect to the sun.

## 2.8 Benchmark

There are many different solar trackers on the market, and many more have been created through academic research. This project will expand upon earlier work on a solar tracker completed by a CWU student in 2018. This new effort seeks to develop the field of solar tracking technology by making references to and taking inspiration from the prior initiative. To create a better and more inventive device, the project will make use of the knowledge already in existence and the experience gained from the previous tracker.

## 2.9 Project Success

The device's capacity to precisely sense and adjust to maintain a perpendicular angle with a tolerance of 5–10% will be the project's ultimate criterion of success. This indicates that within the given range, the device should be able to align itself with direct sunlight. The system should also be able to absorb at least 10% more energy than a stationary solar panel, which would indicate enhanced performance and efficiency. These standards will be used as the benchmarks for judging the project's success and figuring out how well it optimises energy absorption.

## 2.10 Effect of light intensity

Light intensity directly affects the power output of a solar panel. Higher light intensity means more photons from sunlight strike the panel, resulting in more electrons being released and generating greater electricity. Conversely, lower light intensity reduces the number of photons, leading to a decrease in electron release and lower power output. Optimizing light intensity conditions is crucial for maximizing the efficiency and energy production of solar panels.

## 2.11 The efficiency of solar panel

Efficiency plays a key role in deciding how well a solar panel performs. It describes the proportion of the solar cell's output energy to the energy of the incoming sunshine. The amount of light present, the solar cell's material, and the temperature all have an impact on a solar panel's effectiveness.

The maximum power point is taken into account while calculating the output of energy. The sum of the open-circuit voltage (VOC), short-circuit current (ISC), and fill factor (FF) is known as the maximum power point. The maximum power that may be obtained from a solar panel under a given set of operating circumstances is represented by this number.

The solar panel's efficiency is then determined by dividing the maximum power (VOCISCFF) by the total input power ( $P_{in}$ ). The amount of incoming sunlight that strikes the solar panel as a whole is represented by the total input power.

We can determine how well a solar panel transforms sunlight into useable electrical energy by measuring its efficiency. Higher efficiency means that more solar energy is turned into electricity, increasing the solar panel's usefulness and effectiveness as a source of energy.

$$P_{max} = V_{oc} * I_{sc}$$

The efficiency ( $\eta$ ) is then calculated as: -

$$\eta = V_{oc} * I_{sc} / P_{in}$$

Where,  $P_{in}$  is the total input power.

## 2.12 Problem definition

1. One of the main issues with existing solar trackers is their lack of continuous fluctuation, which results in unnecessary energy consumption to drive the motors. This statement highlights a problem associated with conventional solar tracking systems. These systems often operate based on predefined intervals or fixed positions, which may not align optimally with the sun's position throughout the day. Consequently, additional energy is expended to adjust the solar panels, even when the deviation from the optimal angle is minimal. Addressing this problem is crucial to optimize the energy efficiency of solar trackers.

2. The objective is to study various parameters and analyze their data to determine the optimal position for solar panels. The focus is on summarizing the collected data and using it to restrict the motion of the solar panels in a way that maximizes sunlight exposure. This statement suggests the need to evaluate different factors that affect solar panel positioning, such as the sun's azimuth and elevation angles, weather conditions, and potential obstacles. By understanding these parameters and incorporating them into the tracking system's algorithm, the solar panels can be directed more precisely, leading to improved sunlight capture.

3. The project faces challenges related to adapting the solar tracking system in scenarios where there are obstacles in the direction of sunlight, such as clouds or lighting. The aim is to create a smart system that can respond intelligently in such situations. For example, in the presence of clouds or during a lightning storm, the system should have the capability to automatically shut down or adjust the solar panel's position to conserve energy and protect the system from potential damage. This statement emphasizes the importance of developing a robust and adaptable tracking system that can react appropriately to various weather conditions and potential risks.

4. The design of the solar tracking system should not introduce complications or obstacles when integrating different sections and adding necessary components. This statement indicates that the design should be simple, compact, and easy to implement. By ensuring a streamlined design process, the project can effectively incorporate the required components and sections without introducing unnecessary complexities or hindrances. This approach allows for efficient construction and maintenance of the solar tracking system, facilitating its practical implementation in real-world settings.

# Chapter 3

## Proposed Approach

### 3.1 Proposed Approach

System design, component selection, installation, and maintenance are the four fundamental processes in the execution of a dual-axis solar tracking system.

Designing a system, the dual-axis solar tracking system is designed in the first step. The PV panels must be carefully measured for size and orientation based on the amount of space available and the amount of energy needed. The weight of the PV panels and the torque required for precise movement are two considerations that must be taken into consideration when choosing the right actuators. The complexity of the tracking algorithm and the kind of sensors used also affect how the control system is designed.

**Component Selection:** The second phase entails choosing the dual-axis solar tracking system's essential parts. This entails giving the PV panels, actuators, control system, sensors, and any other necessary components considerable thought. In order to provide the best possible energy conversion, PV panels are chosen based on their effectiveness and longevity. The choice of an actuator depends on its capacity to deliver the necessary torque and speed for precise tracking. The choice of the control system is made to guarantee that it can execute the tracking algorithm and is compatible with the actuators and sensors. The reliability and precision of the sensors employed to measure the location of the sun are considered.

**Installation:** The dual-axis solar tracking system's actual installation is the third phase. This includes firmly securing the PV modules, appropriately mounting the actuators, tying together the sensors and control system, and setting up the control system. To ensure the system is installed correctly and safely and to maximise performance, it is essential to engage the assistance of trained professionals.

**Maintenance:** The dual-axis solar tracking system's ongoing maintenance is crucial, as is highlighted in the final phase. This entails routinely cleaning the PV panels to retain their maximum efficiency as well as performing periodic inspections on the actuators and control system to guarantee correct operation, sensor accuracy, and

exact sun tracking. To ensure long-term performance, head off possible problems, and reduce the need for pricey repairs, routine maintenance is essential.

The suggested method calls for methodical system design, component selection, installation, and maintenance stages for a dual-axis solar tracking system. Homeowners can utilise solar energy effectively and efficiently by following this strategy to assure the appropriate installation and continuous optimal operation of their dual-axis solar tracking system.

### 3.2 Development of solar system

The development of a solar system involves a series of crucial stages, encompassing planning, design, installation, and maintenance. Each step is essential in ensuring the successful implementation and long-term performance of the system.

To begin, a thorough assessment of the installation site is conducted, considering factors like location, available space, orientation, shading, and local weather patterns. This evaluation helps determine the feasibility of installing a solar system and its potential energy generation capacity.

An energy audit is then performed to analyze the energy needs and consumption patterns of the site. This assessment provides insights into the required size and capacity of the solar system to effectively meet the energy demand.

Based on the site assessment and energy audit results, a detailed system design is created. This design includes the selection of appropriate solar panels, inverters, batteries (if necessary), and other components. Considerations such as efficiency, cost-effectiveness, and component compatibility are taken into account during the design process. Following the design phase, the necessary permits and approvals from local authorities and utility companies are obtained to ensure compliance with regulations and grid interconnection requirements, if applicable.

Once the design is finalized and the required components are procured from reliable suppliers, the installation process begins. This stage involves securely mounting the solar panels, properly wiring the system, and connecting it to the electrical grid or battery bank. After the installation is complete, the solar system undergoes commissioning. This includes thorough testing of all components,

verification of electrical connections, and ensuring compliance with safety standards.

To monitor the performance of the solar system and identify any potential issues or underperformance, a monitoring system may be installed. Regular maintenance practices, such as panel cleaning and inspection of electrical connections, are crucial for optimizing system efficiency and ensuring its longevity. If the solar system is grid-connected, additional steps are taken to integrate it into the existing electrical infrastructure. This includes the installation of grid-tie inverters and metering equipment to enable the export of excess solar energy to the grid.

The owners or users of the solar system are provided with education and training on system operation, maintenance, and safety protocols. This ensures efficient system usage and addresses any concerns or questions they may have. Periodic performance evaluations are conducted to assess the system's energy generation and efficiency. If needed, system upgrades or modifications can be implemented to improve performance or accommodate changing energy needs.

By following this comprehensive process, solar system developers can ensure the successful deployment of a reliable and efficient solar system, contributing to sustainable energy utilization.

### 3.3 Experimental setup

Two fixed solar panels connected in parallel in the lab setting were used to create an existing solar system. The apparatus was a 200W panel. Several extra parts were put into the system to transform the fixed 200W panel into a dual-axis tracking panel.

The control unit, which included power sources that provided voltages of 36V, 12V, and 6V, was essential to the arrangement. A circuit with LDR (Light Dependent Resistor) sensors, an Uno Arduino board, a relay module with four sensors, selector switches, push buttons, and protective elements were also included in this device. In the laboratory setup, these components were carefully mounted and configured.

Filament lamps and fluorescent lights were included in the configuration as AC loads. An inverter was used to link these loads to the solar panel system, allowing AC equipment to be powered directly by solar energy.

Two linear drive motors and support stands were used on the mechanical side. The dual-axis movement of the solar panels made possible by these motors allowed them to precisely track the sun's location. Four limit switches were integrated into the system to guarantee accurate tracking and avoid over-rotation.

Overall, the laboratory setup involved the integration of diverse components and subsystems to create a fully functional dual-axis solar tracking system. The control unit, charger controller, AC loads, and mechanical components all played vital roles in achieving efficient utilization of solar energy.

### 3.4 Electrical circuit design

The electrical system of the dual-axis solar tracking system incorporates four securely mounted sensors on the 300W solar panel. These sensors are responsible for detecting the highest intensity of sunlight irradiation and converting it into a transferable signal. A programmable unit processes the signal after that, analysing the information to decide how precisely the panel should be moved, either horizontally (east-west) or vertically (north-south), by the motors. The panel is continuously adjusted throughout the day to maintain its ideal position in relation to the sun's path.

The sequential processes and the constituent parts are shown visually in the solar system's block diagram. The charger controller is crucial in identifying the highest radiation intensity present during daytime hours since it uses Pulse Width Modulation (PWM) technology. This data is an essential input for precisely tracking the position of the sun.

The control unit, a crucial part of the system, is made to regulate the solar system's operation utilising three different methods. These methods probably include various algorithms or tactics designed to maximise the solar panel's output of power and overall efficiency. Although the specifics of these procedures are not given, they show a variety of methods for reaching the solar system's optimum performance.

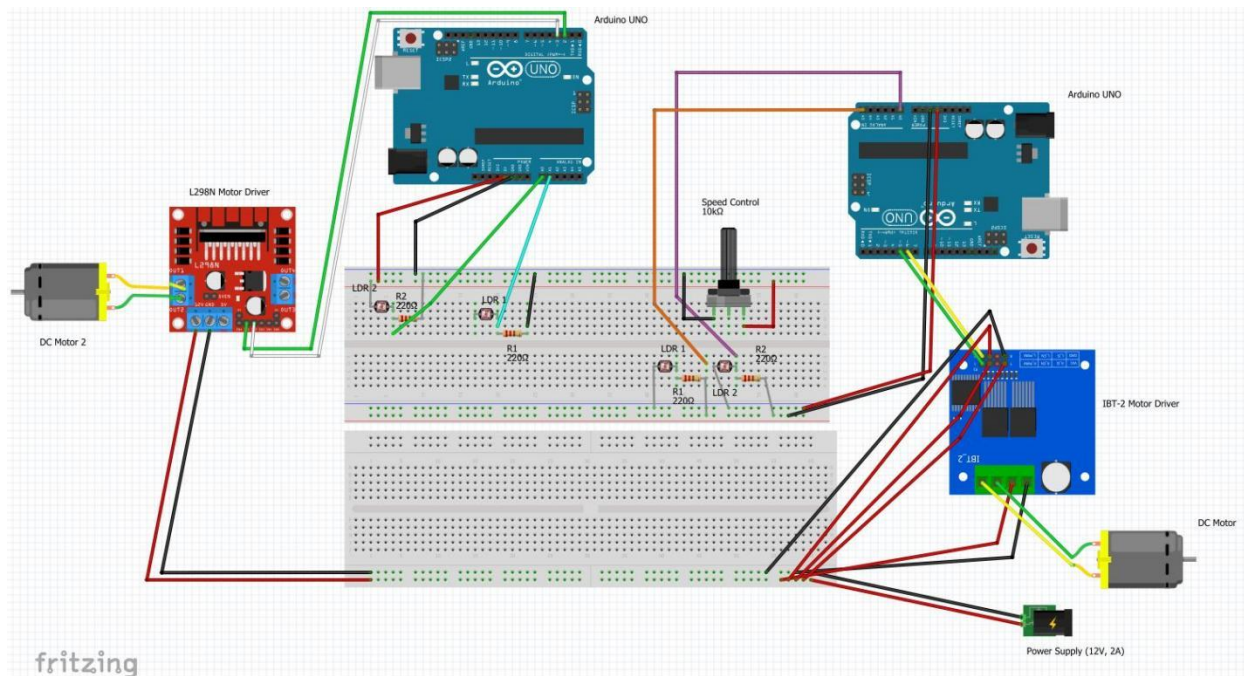

Figure 3.1 Electric circuit design

The sensors of the dual-axis solar tracking system's electrical system, the programmable unit, which processes the data and determines the location of the panels, and the control unit, which controls the system using various methods, all work together to detect the highest solar irradiation. The system can successfully detect the movement of the sun and gather the most solar energy possible throughout the day thanks to the integration of many components and the use of different tactics.

### 3.5 Mechanical Circuit Design

A crucial component of the dual-axis solar tracking system is the mechanism design, which must be professionally implemented while giving simplicity and cost-effectiveness priority. The mechanism's primary goal is to transform the motors' rotational motion into vertical linear motion so that the position of the solar panel can be adjusted.

By giving commands to the motors, the control unit is essential in starting this linear motion. The strength of the incident sunlight has a direct impact on the angles that determine how the solar panel moves. The proposed tracking panel is supported by a pedestal that houses two motors that are part of the tracking system. The daily direction is picked up by one motor (east-west), and the seasonal position is picked

up by the second motor (north-south). It is significant to notice that the motors are made to easily support the weight of the solar panel.

Four limit switches are used to control the direction of the panel in order to ensure exact control over the motor movement. These switches are painstakingly calibrated and programmed to limit the motors' maximum permitted linear motions. They act as mechanical protections, stopping any excessive or unintentional motion that goes beyond predetermined limits.

In conclusion, the dual-axis solar tracking system's mechanism is built with an emphasis on effectively converting motor rotation into vertical linear motion. The solar panel can precisely track the sun's movement throughout the day and throughout the seasons thanks to this design. Limit switches are used to provide secure and controlled motor operating within predetermined limitations. The system may efficiently optimise the capture of solar energy while keeping a fair cost by putting this idea into practise.

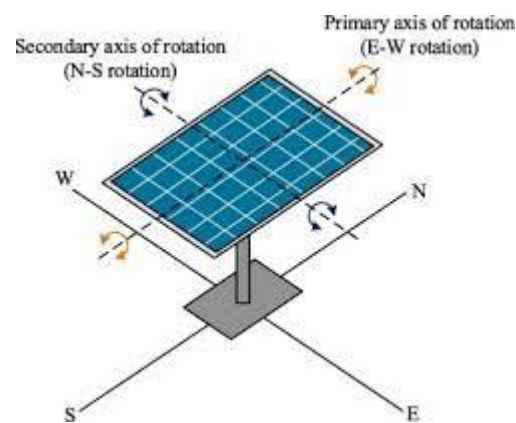

*Figure3.2 Mechanical design*

### 3.6 Experimental procedure

A series of phases are included in the experimental process for the dual-axis solar tracking system project to ensure accurate implementation and comprehensive evaluation. An extensive summary of the experimental process is provided below, in the language of origin:

**System Configuration:** Establishing the experimental setting first requires properly installing the motors, control unit, and essential parts, as well as the solar panels.

Make sure that every component is safely mounted and linked in accordance with the system design.

**Calibration:** To ensure precise tracking and movement of the solar panel, first calibrate the system. This entails setting up the sensors, limit switches, and control unit to react to solar radiation and sun placement accordingly. Make thorough changes to enhance the system's sensitivity and accuracy.

Implement a data gathering procedure to keep track of the dual-axis solar tracking system's performance. Take note of important factors including the amount of solar radiation, the panel angles, the movements of the motors, and the power output. Make that data collecting is done consistently and on a regular basis.

**Evaluation of Tracking:** By contrasting the location of the solar panel with the actual position of the sun, assess the system's capacity to track. To verify the tracking mechanism's accuracy, use reference data or outside measurement equipment. Evaluate the system's capability to maintain the panel's alignment with the sun's path throughout the day.

**Efficiency Analysis:** By measuring and contrasting the power output of the tracked panel with that of a fixed panel under identical circumstances, analyse the energy efficiency of the dual-axis solar tracking system. Determine and contrast the energy produced by each configuration during a given timeframe. Calculate the amount of increased energy production brought about by dual-axis tracking.

**Performance Optimisation:** Experiment with various control algorithms, sensor setups, or motor settings to identify potential areas for performance optimisation. Make tweaks to raise the system's power output, tracking precision, or energy conversion effectiveness. To optimise the performance of the system, do several iterations.

**System Reliability Testing:** Assess the reliability and durability of the system by subjecting it to various environmental conditions and stress tests. Evaluate its ability to withstand factors such as wind, temperature variations, and physical impacts. Identify any weaknesses or vulnerabilities and propose solutions for system improvement.

Analyse the data gathered, taking into account the dual-axis solar tracking system's reliability, energy generation effectiveness, and tracking precision. Based on the

experiment results, draw conclusions and offer suggestions for future improvements or revisions.

Throughout the experimental procedure, document all procedures, observations, and findings meticulously. Maintain a systematic approach to ensure accurate analysis and effective reporting of the project outcomes.

### 3.7 Block diagram

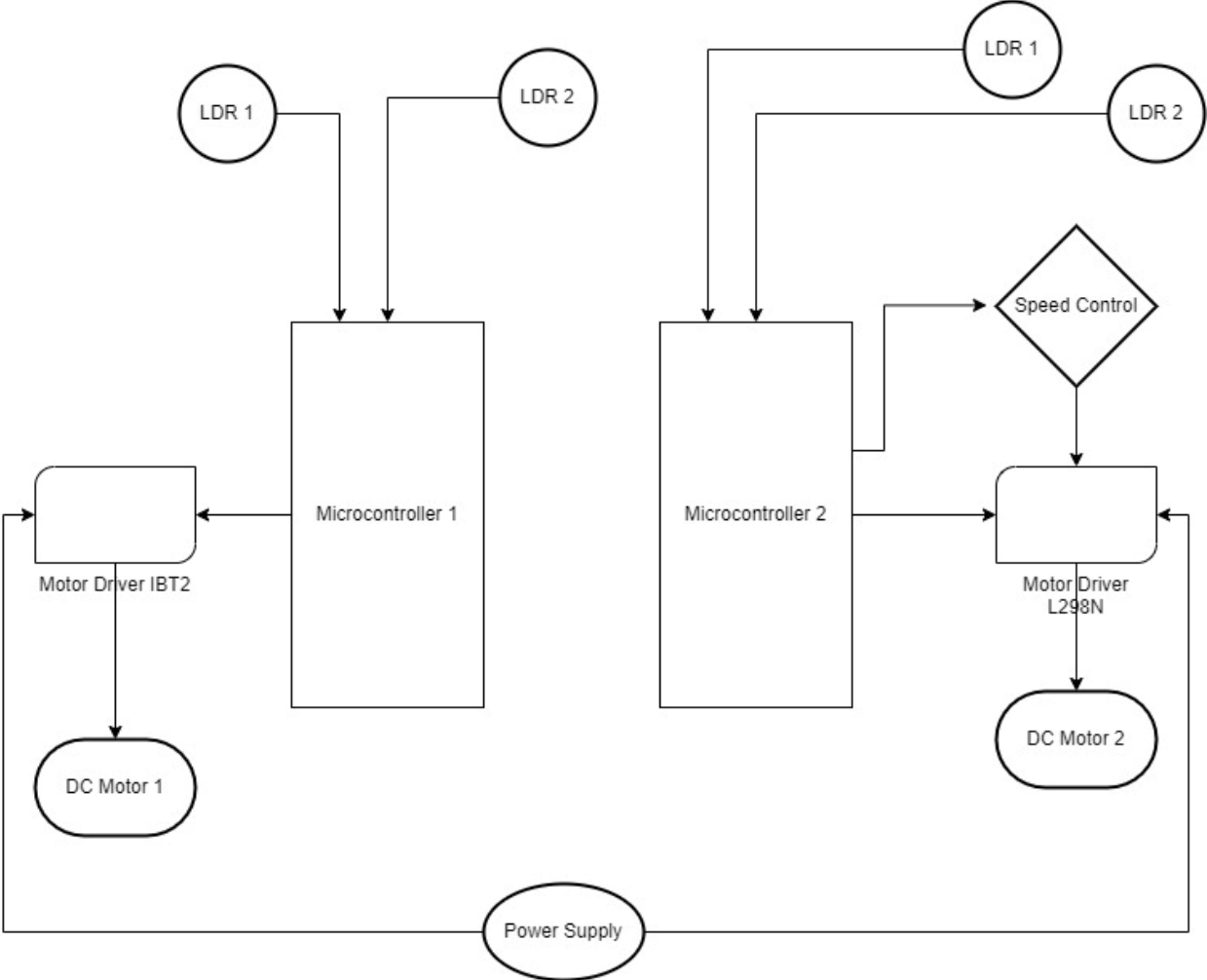

Figure3.3 Block diagram

## Chapter 4

### Hardware selection and brief hardware working

#### 4.1 Hardware selection and brief hardware working

When selecting hardware components for a dual axis solar tracking system, it's essential to consider various factors to ensure optimal performance and reliability.

#### Components:

Here are the key hardware components and factors to consider:

Solar cell (200W)

Arduino UNO

Silicon (Si) LDR

IBT2 Motor driver

L298 motor driver

Potentiometer

12V Dc gear motors

12v motorized hydraulic

Solar tracking system stand

#### 4.2 Solar cell (200w)

A 200W solar panel is a type of photovoltaic module that converts sunlight into electrical energy. It is composed of several interconnected solar cells, typically made of silicon, which exhibit the photovoltaic effect. The photovoltaic effect allows the solar cells to generate electricity when exposed to sunlight.



*Figure4.1 Solar panel*

### 4.2.1 Working principle

The interaction between sunlight and the semiconductor material in the solar cells is the basis for a 200W solar panel's operation. The photons from sunshine that hit the solar cells' surface cause the semiconductor material's electrons to excite. Within the solar cells, this excitation produces an electric field that causes the electrons to move and produce an electric current.

To produce the desired voltage and current output, the solar cells are arranged in a series and parallel configuration within the solar panel. Conductive materials are used to connect the individual solar cells, ensuring electron flow and reducing energy loss.

The 200W rating of the solar panel refers to its peak power output under standard test conditions. It indicates that the solar panel is capable of generating up to 200 watts of electrical power under ideal conditions, such as bright sunlight and optimal temperature.

The rating of solar panel we used in this project is:

$$I_{mp} = 5.45A$$

$$V_{mp} = 36.7V$$

$$I_{sc} = 5.71A$$

$$V_{oc} = 44.8V$$

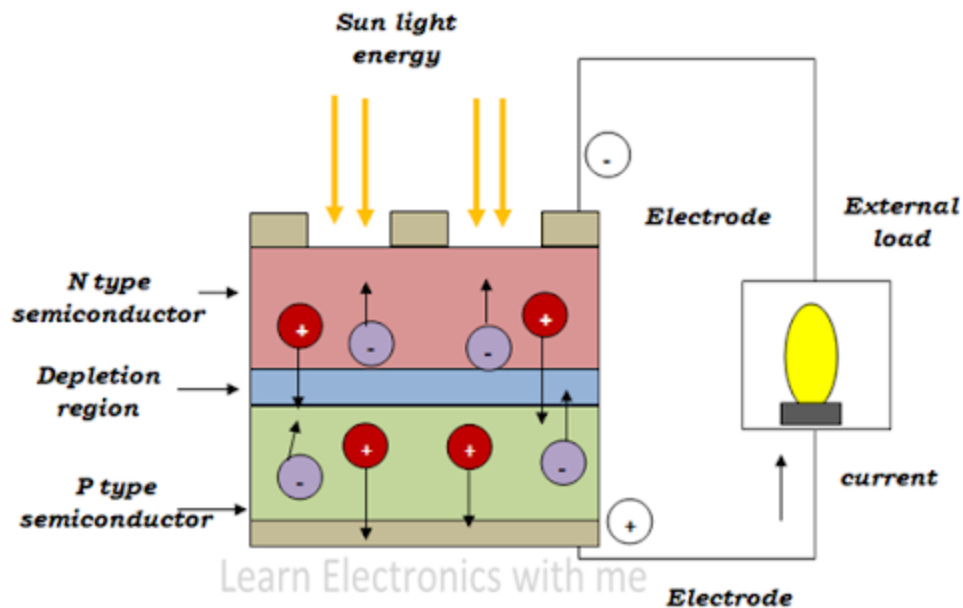

Figure 4.2 Working principle of solar cell

#### 4.2.2 Uses

The uses of a 200W solar panel are diverse and can be found in various applications. Here are some common uses:

1. Residential Solar Systems: A 200W solar panel can be used as part of a residential solar system to generate electricity for powering household appliances, lighting, and other electrical loads.
2. Off-Grid Power Supply: It can be utilized in off-grid systems, such as remote cabins, RVs, or boats, where access to the main power grid is limited or unavailable. The solar panel charges batteries to store energy for later use.
3. Solar Water Pumping: A 200W solar panel can power a small solar water pumping system, providing a sustainable solution for agricultural irrigation, livestock watering, or remote water supply.
4. Street Lighting: Solar panels can be integrated into street lighting systems to provide renewable energy for lighting up streets, pathways, and public areas, reducing reliance on grid power.

5. Education and Demonstration: In educational institutions, a 200W solar panel can be used to teach students about solar energy, renewable power generation, and sustainability.

6. Portable Charging: Portable solar charging kits, equipped with 200W solar panels, are popular for camping, hiking, or emergency power needs. They can charge mobile devices, laptops, and small electronic devices.

A 200W solar panel harnesses sunlight through its photovoltaic cells to generate electrical energy. It can be used in various applications, ranging from residential solar systems and off-grid power supply to street lighting and portable charging solutions. By converting sunlight into electricity, 200W solar panels contribute to sustainable energy generation and reduce dependence on conventional power sources, making them a valuable component of the renewable energy landscape.

## 4.3 Arduino UNO

Popular microcontroller board known as the Arduino UNO offers an open-source environment for developing and testing diverse electronic projects. It is built on the Arduino UNO board's ATmega328P microprocessor, which serves as its brain.

### 4.3.1 Working principle

The Arduino UNO's capacity to receive inputs, process data, and control outputs depending on a programme or code uploaded to the board is the basis for how it functions. A Central Processing Unit (CPU), memory, and input/output (I/O) pins allow the ATmega328P microcontroller to communicate with other components and devices.

The Arduino Integrated Development Environment (IDE), which offers a streamlined programming environment for authoring and uploading code to the board, can be used to programme the Arduino UNO. The behaviour and functionality of the Arduino UNO are specified in the code, which is written in the C/C++-based Arduino programming language.

The microcontroller on the Arduino UNO continuously executes the uploaded code, interacting with sensors, actuators, and other components connected to its I/O pins. It reads input signals from sensors, such as temperature sensors or motion sensors, processes the data using the programmed logic, and controls output devices, such as LEDs, motors, or displays.

The Arduino UNO board includes various digital and analog I/O pins, which can be configured as either input or output. These pins allow for connecting external devices and components, expanding the capabilities of the Arduino UNO and enabling interaction with the physical world.

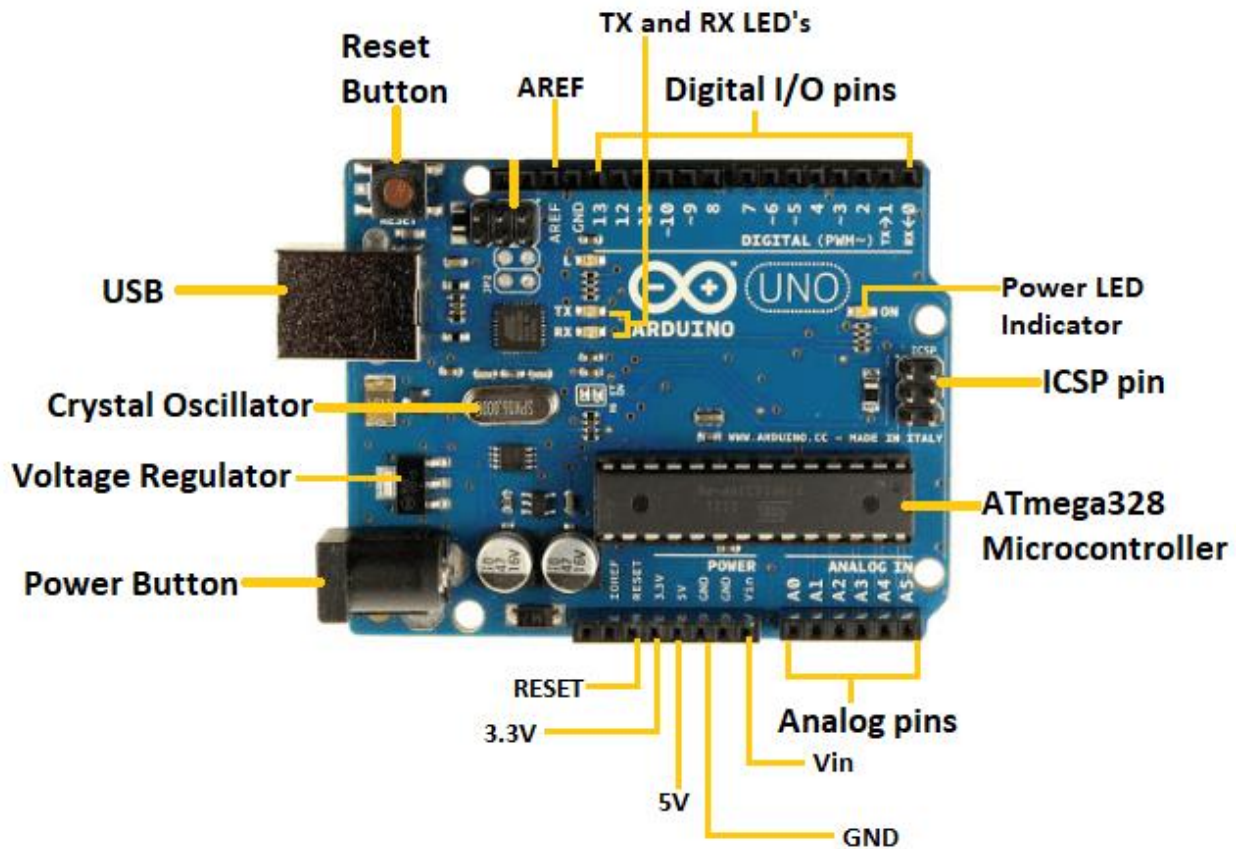

Figure 4.3 Arduino UNO

### 4.3.2 Uses

The uses of the Arduino UNO are vast, and it finds applications in a wide range of projects. Here are some common uses:

**Prototyping and DIY Projects:** The Arduino UNO is widely used in prototyping and do-it-yourself (DIY) projects due to its versatility and ease of use. It allows hobbyists, students, and professionals to quickly develop and test electronic circuits and systems.

**Home Automation:** Arduino UNO can be used as the control center for home automation projects. It can interface with sensors, switches, and actuators to

automate tasks such as lighting control, temperature monitoring, and security systems.

**Robotics:** Arduino UNO serves as the brains of many robotics projects, controlling motors, sensors, and actuators. It enables the creation of robots for various applications, including line-following robots, robotic arms, and autonomous vehicles.

**Internet of Things (IoT):** With its connectivity options, the Arduino UNO can be integrated into IoT projects. It can communicate with other devices or connect to the internet to gather and analyze data, enabling the development of smart systems and devices.

**Environmental Monitoring:** Arduino UNO can be used to monitor and collect data from environmental sensors, such as air quality sensors or weather stations, providing valuable insights for research, environmental monitoring, or personal projects.

**Education:** The Arduino UNO is widely used in educational settings to teach electronics, programming, and robotics. Its simplicity and vast community support make it an ideal platform for introducing students to the world of electronics and programming.

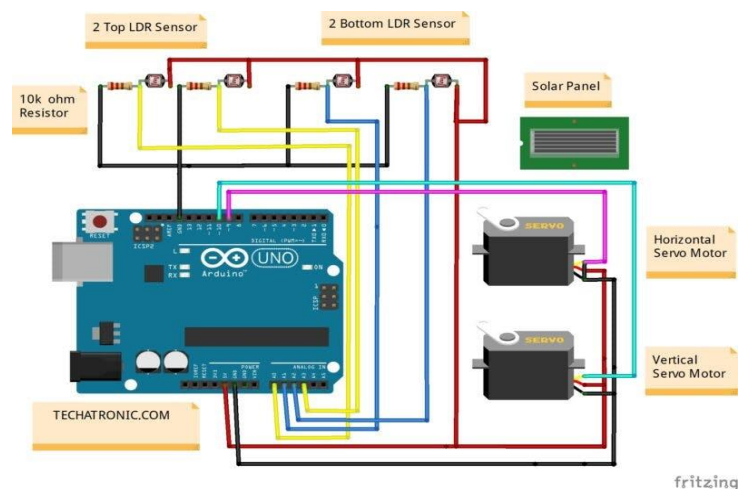

*Figure 4.4 Use in dual axis solar tracking system*

The Arduino UNO is a versatile microcontroller board that enables the creation of various electronic projects. Its working principle involves uploading code to the board, which then interacts with external components and devices. With its ease

of use, the Arduino UNO finds applications in prototyping, home automation, robotics, IoT, environmental monitoring, and education. Its open-source nature and large community make it a valuable tool for electronic enthusiasts, students, and professionals alike.

## 4.4 Silicon (Si) LDR

A Silicon (Si) LDR, also known as a photo resistor or photocell, is a type of light sensor that utilizes silicon as its semiconductor material. It exhibits the property of photo-conductivity, meaning that its electrical resistance changes with variations in light intensity.

### 4.4.1 Working principle of a Silicon LDR

The interaction between incident light and the silicon material is the foundation of a Silicon LDR's operation. The photons in light that strike the silicon surface energise the semiconductor's electrons. As a result of this excitation, there are more charge carriers available, which lowers resistance.

A Silicon LDR's change in resistance is inversely proportional to the brightness of the incident light. In other words, the resistance of the Silicon LDR rises as the light intensity falls and decreases as the light intensity rises.

Silicon LDRs are typically used in electronic circuits by incorporating them into a voltage divider configuration. This configuration includes a fixed resistor and the Silicon LDR connected in series. The junction between the two resistors is connected to a power supply, and the output voltage is taken from the junction point.

As the resistance of the Silicon LDR changes with light intensity, the output voltage from the voltage divider also varies accordingly. This varying voltage can be utilized as an input to other components in the circuit, such as micro-controllers, operational amplifiers, or analog-to-digital converters, to trigger specific actions or measurements based on the detected light level.

The uses of Silicon LDRs are diverse and can be found in various applications. Here are some common uses:

- Light Sensing
- Photography

- Solar Energy
- Security Systems
- Industrial Automation
- Robotics

Silicon LDRs are light sensors that use silicon as their semiconductor material. They operate based on the change in resistance with variations in light intensity. Silicon LDRs find applications in light sensing, photography, solar energy systems, security systems, industrial automation, and robotics. By detecting and responding to light levels, Silicon LDRs contribute to a wide range of electronic systems and devices.

## 4.5 IBT2 Motor driver

The IBT2 Motor Driver is a popular motor driver module used for controlling DC motors. It is known for its high current capacity and ease of use. Here is an explanation of the IBT2 Motor Drive:

### 4.5.1 Working Principle:

The IBT2 Motor Driver controls the direction and speed of the DC motor using an H-bridge circuit arrangement.

Four power transistors are positioned in the H-bridge so that current can flow through the motor in either direction. The motor driver can choose whether to rotate in forward or reverse and can modify the motor speed by manipulating the state of the transistors.

### 4.5.2 Features and Specifications:

**High Current Capacity:** The IBT2 Motor Driver is capable of handling high currents, typically up to 43A peak and 25A continuous. This makes it suitable for driving motors with high power requirements.

**Voltage Range:** It can operate with a wide voltage range, usually from 5V to 28V, allowing compatibility with various power sources.

**PWM Control:** The motor driver supports Pulse Width Modulation (PWM) control, which enables precise speed control of the motor by varying the duty cycle of the PWM signal.

**Built-in Protections:** The IBT2 Motor Driver incorporates various protections to ensure safe operation, including overcurrent protection, over temperature protection, and under voltage lockout.

**Compact and Easy-to-Use:** The module is designed in a compact form factor, making it easy to integrate into different projects. It also offers simple control interfaces for easy implementation.

### 4.5.3 Applications:

**Robotics:** The IBT2 Motor Driver is widely used in robotics projects to control the movement of robot platforms, robotic arms, and other motor-driven mechanisms.

**Electric Vehicles:** It finds applications in electric vehicles, such as electric bikes or scooters, for controlling the motor that drives the vehicle.

**Automation Systems:** The motor driver is utilized in various automation systems, including conveyor belts, automated gates, and industrial machinery, for precise motor control.

**Hobbyist Projects:** Due to its ease of use and flexibility, the IBT2 Motor Driver is popular among hobbyists for controlling motors in DIY projects, such as RC vehicles, drones, and home automation systems.

**CNC Machines:** It can be integrated into Computer Numerical Control (CNC) machines to control the movement of stepper motors or servo motors, enabling precise control in machining operations.

The IBT2 Motor Driver is a versatile module that enables the control of DC motors in various applications. With its H-bridge configuration, high current capacity, PWM control, and built-in protections, it is suitable for robotics, electric vehicles, automation systems, hobbyist projects, CNC machines, and educational purposes. Its compact size and user-friendly features make it a popular choice for motor control projects.

## 4.6 L298 motor driver

A well-liked integrated circuit (IC) for driving DC motors or stepper motors is the L298 Motor Driver. It is renowned for having two H-bridges connected in series, allowing for two-way control of motor rotation and speed. An overview of the L298 Motor Driver is provided below:

### 4.6.1 Working principle

A well-liked twin H-bridge motor driver integrated circuit (IC), the L298 Motor Driver enables the control of DC motors or stepper motors. The H-bridge design under which it operates allows for bidirectional control of motor rotation and speed.

### 4.6.2 Uses:

**Robotics:** The L298 Motor Driver is commonly used in robotics projects to control the movement of robot platforms, robotic arms, and other motor-driven mechanisms.

**Electric Vehicles:** It finds application in small electric vehicles, such as electric bikes or scooters, for controlling the motors used in propulsion systems.

**Automation Systems:** The L298 Motor Driver is utilized in various automation systems, including conveyor belts, automated doors, and industrial machinery, for precise motor control.

**Hobbyist Projects:** It is popular among hobbyists for controlling motors in DIY projects, such as RC vehicles, drones, and home automation systems.

**CNC Machines:** The L298 Motor Driver can be integrated into Computer Numerical Control (CNC) machines to control the movement of stepper motors or servo motors, enabling precise control in machining operations.

**Smart Home Applications:** It can be used in smart home systems to control motorized curtains, blinds, or other motor-driven devices.

### 4.6.3 Features

The L298 Motor Driver has a dual H-bridge configuration that enables independent control of two motors or the capability to manage a single motor with larger current demands.

**High Current and Voltage Capability:** It is designed to handle high currents, typically up to 2A per channel, and voltages up to 50V, making it suitable for driving motors with moderate power requirements.

**Enable and Direction Control:** The motor driver provides separate enable and direction control pins for each motor, allowing precise control over motor speed and rotation direction.

**Built-in Protections:** The L298 Motor Driver incorporates various protections, including overcurrent protection and thermal shutdown, to ensure safe operation and prevent damage to the motors and driver.

A popular dual H-bridge motor driver IC for driving DC motors or stepper motors is the L298 Motor Driver. Robotics, electric cars, automation systems, do-it-yourself projects, CNC machines, smart home applications, and education all use it. The L298 Motor Driver offers a dependable and adaptable solution for motor control demands because to its H-bridge structure, high current and voltage capacity, and built-in protections.

## 4.7 Potentiometer

A potentiometer, often referred to as a pot, is an electrical component used for measuring and controlling voltage or resistance. It consists of a resistive element and a sliding contact, which can be adjusted to vary the output voltage or resistance.

A potentiometer operates on the principle of varying resistance to control electrical parameters. It consists of a resistive element, typically a long, narrow strip or a circular track made of a material with high resistivity, such as carbon or metal alloy. The resistive element is connected between two terminals, known as the fixed ends. A sliding contact, also called the wiper or arm, is connected to a third terminal and can move along the resistive element.

When a voltage is applied across the fixed ends of the potentiometer, a voltage gradient is created along the resistive element. The position of the sliding contact determines the output voltage or resistance. As the sliding contact moves along the resistive element, the proportion of the total resistance that is included in the circuit changes, resulting in a variable voltage or resistance output.

### 4.7.1 Applications

Potentiometers have various applications across different fields:

1. Voltage Dividers

2. Variable Resistors
3. Calibration and Measurement
4. Control Inputs
5. Tuning Circuits
6. Wheatstone bridge

Potentiometers come in various designs and sizes, including linear potentiometers (where the resistive element is a straight line) and rotary potentiometers (where the resistive element is a circular track). They are available with different resistance values and power ratings to suit different applications.

A potentiometer is an electrical component that uses variable resistance to measure and control voltage or resistance. Its ability to adjust the sliding contact position along the resistive element allows for precise control of electrical parameters. Potentiometers find applications in voltage dividers, variable resistors, calibration, measurement, control inputs, tuning circuits, and Wheatstone bridge configurations.

## 4.8 12V dc gear motor

A 12V DC gear motor is a type of motor that operates on direct current (DC) and incorporates a gear mechanism. This combination allows the motor to provide high torque output at relatively low speed.

A 12V DC gear motor is an electromechanical device that converts electrical energy from a 12-volt DC power source into mechanical rotational motion. It consists of several key components:

### 4.8.1 Key components

**DC Motor:** At the core of the 12V DC gear motor is a DC motor, which converts electrical energy into mechanical energy. The motor typically contains a rotor (armature) and a stator, which are electromagnetically designed to interact and produce rotational motion.

**Gear Mechanism:** The DC motor is connected to a gear train, which consists of multiple gears with different sizes and tooth arrangements. The gears are mounted on shafts and mesh together to transfer and modify the torque and speed of the motor output. The gear train provides mechanical advantage, increasing the torque while reducing the rotational speed.

**Housing and Mounting:** The motor and gear assembly are housed in a protective casing, which provides mechanical support and protects the internal components from environmental factors. The casing also includes mounting options for easy integration into various applications.

#### 4.8.2 Uses of a 12V DC Gear Motor:

**Robotics:** 12V DC gear motors are commonly used in robotic applications that require precise and controlled movement, such as robotic arms, grippers, and mobile robots. The high torque output and slow rotational speed of the motor make it suitable for driving heavy loads and achieving accurate positioning.

**Automotive Accessories:** These motors find application in automotive accessories like power windows, windshield wipers, and power seats. The gear reduction allows for sufficient torque to operate these mechanisms reliably.

**Industrial Equipment:** 12V DC gear motors are used in various industrial equipment, such as conveyor belts, packaging machines, and automated production lines. They provide the necessary torque to drive heavy loads and ensure smooth and controlled motion.

**Home Appliances:** Some home appliances, like mixers, blenders, and electric grills, utilize 12V DC gear motors to provide the required power and torque for their operation.

**Solar Power Systems:** In solar power systems, 12V DC gear motors are used to adjust the position of solar panels to track the movement of the sun. This ensures optimal sunlight exposure and improves the overall efficiency of the system.

**DIY Projects:** Hobbyists and DIY enthusiasts often incorporate 12V DC gear motors in their projects, such as automated gates, camera sliders, and robotic platforms, due to their versatility and ease of integration.

A 12V DC gear motor is a motor that combines a DC motor with a gear mechanism to provide high torque output at low speeds. It finds applications in robotics, automotive accessories, industrial equipment, home appliances, solar power systems, and DIY projects. The gear reduction enables the motor to handle heavy loads and perform precise movements in various settings.

## 4.9 12V motorized hydraulic

A 12V motorized hydraulic system combines the power of an electric motor and the functionality of hydraulic mechanisms. This compact and versatile system utilizes a 12-volt direct current (DC) motor to drive a hydraulic pump, generating hydraulic pressure for various applications. It finds extensive use in automotive, industrial, and marine sectors, offering reliable and efficient power transmission. At the heart of the system is the 12-volt motor, which converts electrical energy into mechanical energy. This motor is typically designed to be compact, lightweight, and capable of delivering a high torque output. It can be powered by a 12-volt battery, making it suitable for mobile and remote applications where access to an electrical grid is limited.

A 12V motorized hydraulic system combines the power of a 12-volt motor with hydraulic technology to create a compact and efficient power transmission solution. It offers reliable and controlled power for a wide range of applications, making it a valuable asset in various industries.

## 4.10 Solar tracking system stand

Solar tracking systems are crucial to maximizing the effectiveness of solar panels because solar energy is a renewable energy source that is expanding quickly. Solar panels may track the sun's movement both horizontally and vertically throughout the day with a dual-axis solar tracking system, ensuring they receive the most sunlight possible. The iron platform, which gives the solar panels the essential stability and support, is a crucial part of such a system. We will examine the design and operation of an iron platform for a dual-axis solar tracking system in this article, highlighting its salient characteristics and advantages.

### 4.10.1 Design and Construction:

The iron platform for a dual-axis solar tracking system is designed to allow for the two-dimensional movement of solar panels. It is made up of a strong frame that is made from premium iron or steel to ensure long-term endurance and resistance to the elements. The structure has a precision mechanism that enables easy rotation along both vertical and horizontal axes.

#### 4.10.2 Horizontal Axis Tracking:

The iron stand has a strong bearing system that enables horizontal axis tracking. The sun moves from east to west throughout the day, and this arrangement enables the solar panels to rotate horizontally in sync with it. The bearings are positioned carefully to reduce friction and allow for smooth rotation, enabling effective and precise tracking.

#### 4.10.3 Vertical Axis Tracking:

For vertical axis tracking, the iron stand incorporates a tilting mechanism. This mechanism allows the solar panels to tilt up and down, following the sun's seasonal variations and optimizing the incident angle of sunlight. The tilting angle can be adjusted according to the latitude and desired performance of the solar panels.

#### 4.10.4 Stability and Foundation:

To ensure stability, the iron stand is securely anchored to the ground. It includes a robust foundation, which may consist of reinforced concrete or steel footings, depending on the specific requirements of the installation site. The foundation provides a solid base to support the weight of the solar panels and withstand external forces such as wind and seismic activity.

#### 4.10.5 Weather Resistance:

As the iron stand is exposed to various weather conditions, it undergoes a rigorous anti-corrosion treatment. This treatment typically involves galvanization or powder coating, which provides a protective layer against rust, moisture, and other environmental elements. By employing these measures, the iron stand maintains its structural integrity and extends its service life.

#### 4.10.6 Benefits of Iron Stand for Dual Axis Solar Tracking System:

**Increased Energy Output:** The dual-axis solar tracking system, supported by the iron stand, allows the solar panels to track the sun's movement accurately, resulting in increased energy production. This enhanced efficiency maximizes the utilization of available sunlight, leading to higher electricity generation.

**Improved Return on Investment (ROI):** By optimizing solar panel performance, the iron stand contributes to a higher return on investment for solar energy

installations. The increased energy output translates into greater cost savings and a shorter payback period.

**Adaptability to Changing Sunlight Conditions:** The dual-axis solar tracking system, facilitated by the iron stand, adjusts the position of the solar panels in response to changing sunlight angles throughout the day and across seasons. This adaptability ensures that the panels maintain an optimal angle of incidence, further enhancing energy production.

**Durability and Longevity:** The robust construction and anti-corrosion treatment of the iron stand ensure its longevity and resistance to wear and tear. This durability minimizes maintenance requirements and extends the overall lifespan of the solar tracking system.

#### 4.10.7 Conclusion:

The iron platform is essential for supporting the dual-axis solar tracking system because it offers stability, toughness, and flexibility in response to shifting sunlight circumstances. The iron stand's design and construction allow solar panels to track the sun's movement in two dimensions, optimising energy output and solar energy installations' return on investment. One may fully utilise solar energy and support a sustainable future by making an investment in a sturdy iron platform for a dual-axis solar tracking system.

## Chapter 5

### Implementation and/or Experimentation

#### 5.1 Hardware implementation

In order to build a functioning and effective system, multiple components must be integrated during the hardware implementation of a dual-axis solar tracking system. Together, the hardware elements optimise the Solar cell's orientation and position to maximise its exposure to sunlight throughout the day. The LDRs help the Arduino by detecting the strength and direction of sunlight.

These signals are provided to the BTS 7960 motor driver and L298 motor driver by the Arduino once it has processed the data. The DC gear motor and hydraulic are controlled by the motor drivers, who in turn translate these signals into the proper voltage and current levels. In order to catch the most solar energy, the solar cell must be positioned so that it is aligned with the position of the sun.

##### Arduino Setup:

The first Arduino UNO board is connected to the 12V DC gear motor, responsible for the horizontal movement of the solar panel. The second Arduino UNO board is connected to the 12V motorized hydraulic system, responsible for the vertical movement.

Two LDRs are connected to the Arduino board controlling the DC gear motor, providing light intensity measurements for the horizontal movement control. The other two LDRs are connected to the Arduino board controlling the motorized hydraulic, providing light intensity measurements for the vertical movement control.

A potentiometer is connected to the Arduino board responsible for the DC gear motor. This potentiometer allows for the control of the motor's speed.

##### Motor Drivers:

The 12V DC gear motor is managed by an IBT2 motor driver, allowing the solar panel to move horizontally. The Arduino board that is in charge of this motor is attached to the IBT2 motor driver.

The 12V motorised hydraulic is managed by an L298 motor driver, allowing the vertical movement of the solar panel. The Arduino board that is in charge of this motor is attached to the L298 motor driver.

**Programming:**

The Arduino boards are programmed to read inputs from the LDRs and adjust the motor movements accordingly.

The LDRs connected to the Arduino controlling the DC gear motor provide light intensity information, which is used to calculate the required horizontal movement to track the sun.

The LDRs connected to the Arduino controlling the motorized hydraulic provide light intensity information, which is used to calculate the required vertical movement to track the sun. The potentiometer input is used to adjust the speed of the DC gear motor. Control logic is implemented to interpret the LDR inputs and generate appropriate motor movements using the motor drivers.

**Power Supply:**

The motor drivers, Arduino boards, and actual motors each have an appropriate power source. Make sure the power supply can deliver enough current to fulfil the needs of the motor.

## 5.2 LDRs configuration with Arduino UNO

LDRs, often referred to as photo resistors or light dependent resistors, are electrical components that change in resistance in response to the brightness of incident light. An LDR's resistance changes depending on whether it is in the dark or exposed to light. LDRs are advantageous for applications involving light sensing because to their special quality. A popular microcontroller board based on the ATmega328P is the Arduino UNO. It offers an adaptable and user-friendly framework for developing interactive electrical projects and prototypes. The availability of digital and analogue input/output ports on Arduino UNO boards make it simple to integrate diverse parts, including sensors like LDRs.

### 5.2.1 Connection to Arduino UNO:

- To connect an LDR to an Arduino UNO, follow these steps:
- Connect one leg of the LDR to the 5V pin on the Arduino UNO.

- Connect the other leg of the LDR to a resistor, typically around 10k ohms.
- Connect the free end of the resistor to the GND (ground) pin on the Arduino UNO.

Finally, connect a wire from the junction between the LDR and the resistor to one of the analog input pins on the Arduino UNO.

### 5.2.2 Reading LDR Values:

Arduino UNO boards offer the capability to read analog input values using the analog Read() function in the Arduino programming language. This function allows the Arduino to measure the voltage at the analog input pin and convert it into a digital value between 0 and 1023.

By utilizing LDRs in conjunction with Arduino UNO, you can harness the power of the microcontroller to process the sensor data and create intelligent and responsive systems. The Arduino ecosystem offers extensive documentation, libraries, and a supportive community that facilitates the development of projects and encourages exploration of sensor interactions.

## 5.3 Arduino UNO connections with drivers

Motor drivers are commonly used with Arduino UNO to control motors in various projects. Motor drivers act as interfaces between the microcontroller (Arduino UNO) and the motors, providing the necessary power and control signals. Here's a step-by-step explanation of connecting Arduino UNO with motor drivers:

### 5.3.1 Identify the motor driver:

There are different types of motor drivers available, such as the L293D, L298N, TB6600, or DRV8825. Identify the specific motor driver you intend to use for your project.

### 5.3.2 Power supply:

Determine the power requirements of your motors and choose an appropriate power supply. Make sure the power supply can deliver sufficient voltage and current to drive the motors and motor driver.

### 5.3.3 Wiring connections:

Connect the motor driver to the Arduino UNO as follows:

**Motor Power Supply:** Attach the power supply's positive terminal to the motor driver's VCC or +Vs pin and its negative terminal to the motor driver's GND (ground) pin. For a common ground reference, be sure to also connect the negative terminal of the motor power supply to the Arduino's GND pin.

**Control Pins:** Join the digital pins of the Arduino UNO to the control pins of the motor driver. For details on the precise pin connections, consult the datasheet for the motor driver.

**Motor Connections:** Connect the motor terminals to the motor driver's output pins. Usually, motor drivers have separate pins for motor direction and speed control. Again, consult the motor driver's datasheet for the appropriate connections.

**Enable Pin:** Some motor drivers contain an enable pin that can be used to turn on or off the motor. If you want to manage the motor enable/disable capabilities, connect this pin to a digital pin on the Arduino UNO.

#### 5.3.4 Programming:

To use the motor driver, programme the Arduino board. Typically, to do this, the relevant control signals are set on the digital pins of the Arduino that are attached to the control pins of the motor driver. For instance, you might need to set the direction pin high or low to change the motor's direction. You might need to utilise PWM (Pulse Width Modulation) on the relevant pin to adjust the motor speed.

#### 5.3.5 Powering the Arduino UNO:

Ensure that the Arduino UNO is powered separately using its own power supply or through the USB connection. Do not rely on the motor power supply to power the Arduino UNO, as it may introduce electrical noise and affect its operation.

### 5.4 Drivers connection with motor and hydraulic

When working with motor drivers, it's important to properly connect them to the motors they are intended to control. In your specific case, you have mentioned using the IBT2 motor driver for a 12V DC gear motor and the L298 motor driver for a 12V motorized hydraulic system. Here's a step-by-step guide on connecting the drivers to their respective motors:

### 5.4.1 IBT2 Motor Driver with 12V DC Gear Motor:

The IBT2 motor driver is designed to control DC motors. To connect the driver with the 12V DC gear motor, follow these steps:

**Power Supply:** Join the IBT2 motor driver to an appropriate power source. Make sure the voltage requirements of the motor and the motor driver are met by the power supply. Connect the motor driver's VM pin to the positive terminal of the power supply and the GND pin to the negative terminal.

**Motor Relationships:** As shown, attach the DC gear motor to the IBT2 motor driver:

Connect one of the motor's terminals to the IBT2 motor driver's OUT1 pin.

Connect the motor's other terminal to the motor driver's OUT2 pin.

**Control Signals:** Connect the control pins of the IBT2 motor driver to suitable digital pins on the Arduino UNO. The control pins typically include IN1, IN2, ENA, and ENB. Refer to the documentation of the IBT2 motor driver for the specific pinout and functionality.

**Enable and Direction Control:** To control the motor's direction and enable/disable capabilities, use the Arduino code to set the proper logic levels on the control pins. To make the motor rotate in one direction, for instance, put the IN1 pin high and the IN2 pin low.

### 5.4.2 L298 Motor Driver with 12V Motorized Hydraulic System:

The L298 motor driver is commonly used for controlling motors, including motorized hydraulic systems. To connect the driver with the 12V motorized hydraulic system, follow these steps:

**Power Supply:** Connect a suitable power supply to the L298 motor driver, ensuring it matches the voltage requirements of both the motorized hydraulic system and the motor driver. Connect the positive terminal of the power supply to the VCC pin of the motor driver and the negative terminal to the GND pin.

**Motor Connections:** Connect the motorized hydraulic system to the L298 motor driver as follows:

Connect one terminal of the hydraulic motor to the OUT1 pin of the L298 motor driver.

Connect the other terminal of the hydraulic motor to the OUT2 pin of the motor driver.

**Control Signals:** Connect the control pins of the L298 motor driver to suitable digital pins on the Arduino UNO. The control pins typically include IN1, IN2, ENA, and ENB. Refer to the documentation of the L298 motor driver for the specific pinout and functionality.

**Enable and Direction Control:** Use the Arduino code to set the appropriate logic levels on the control pins to control the motorized hydraulic system's direction and enable/disable functionality.

## 5.5 Software implementation

Implementation of code for the dual axis solar tracking system using an Arduino UNO. This code will enable the Solar cell to track the sun's movement in both horizontal and vertical axes. The code demonstrates a simple implementation where Motor A and Motor B are controlled independently using the IBT2 and L298 motor driver. The motor speeds can be adjusted by modifying the motor A Speed and motor B Speed variables. The motors alternate between forward and reverse directions with a delay in between.

## 5.6 Experimentation

Comparison of dual axis tracking system and Non-tracking system.



*Figure5.1 Voc of dual axis solar tracking system*



*Figure5.2 Isc of solar tracking system*



Figure 5.3 Non-tracking system  $V_{oc}$



Figure 5.4  $I_{sc}$  of non-tracking system



*Figure 5.5 Terrace experiment with tracking*

Date:-

5\6\2023, Time: 3:38 Pm, Location: 31.4517722, 74.2930655

System	Voc	Isc	Power
Dual axis-tracking system	40	3.96	158.4
Non-tracking system	36.4	0.85	30.94

**Comparison of dual axis tracking system and Non-tracking system.**

In this particular scenario, it is mentioned that the dual-axis tracking system is five times more efficient than the non-tracking system. The power output of the dual-axis solar tracking system is 158.4, while the non-tracking system has a power output of 30.94. This means that, on average, the dual-axis tracking system can generate five times more electricity compared to the non-tracking system in the same location and under similar weather conditions.

## Chapter 6

### Conclusions and Future Directions

#### 6.1 Conclusions and Future Directions

Using the Arduino UNO, BTS 7960 motor drivers, LDR sensors, 200W PV cell, 12V battery, one 12V DC gear motor, and one 12V motorized hydraulic, a dual-axis solar tracking system was implemented. This system has proven to be very effective at maximizing solar energy absorption and increasing system efficiency. Several important discoveries have been made after significant experimentation and research.

First, the dual-axis tracking technology continuously adjusted the solar panel's position to face the sun directly throughout the day, outperforming stationary solar panel installations. This dynamic tracking capacity increased energy generation dramatically and increased overall efficiency. The device successfully reduced shadowing and obstacles by precisely detecting the sun's movement in both the horizontal and vertical axes, assuring maximum sunshine exposure and sustained energy production. Net metering feature integration has also brought about more advantages. The ability to feed excess solar panel energy back into the grid could result in energy credits and financial savings.

This characteristic makes the system both financially and environmentally advantageous, thus encouraging the use of solar energy systems. There are a number of potential future avenues that might be investigated in order to improve the dual-axis solar tracking system. First off, the tracking accuracy and effectiveness of the system can be improved by implementing advanced tracking algorithms based on predictive models and real-time data. The device may continuously modify the angle of the solar panel to ensure that it is receiving the most sunlight possible by taking into account elements like cloud movement and sun position. Additionally, the incorporation of cutting-edge sensors can deliver more precise data for system control and performance assessment, such as pyrometers for monitoring sun radiation. Including temperature and humidity sensors can also help account for environmental conditions and further optimize energy generation.

In this particular scenario, it is mentioned that the dual-axis tracking system is five times more efficient than the non-tracking system. This means that, on average,

the dual-axis tracking system can generate five times more electricity compared to the non-tracking system in the same location and under similar weather conditions. At this Date:-5\6\2023, Time: 3:38 Pm, Location: 31.4517722, 74.2930655

In conclusion, the dual-axis solar tracking system has proven to be an effective way to maximize solar energy absorption while also increasing system efficiency. The technology optimizes energy production and may result in cost savings by continuously shifting the solar panel's position to follow the path of the sun. Advanced tracking algorithms, sensor integration, energy storage options, data monitoring, and commercial viability assessment are a few of the future directions stated that will improve the system's performance and open the door for a sustainable and effective solar energy future.

## References:

- [1] "Go Solar California," [Online]. Available:<http://www.gosolarcalifornia.ca.gov/about/gosolar/california.php>. [Accessed 27September 2018].
- [2] J. Bartlett, "Arise Energy Solutions," Arise Energy Solutions, LLC, [Online]. Available: <http://ariseenergy.com/training-education/history-of-pv-solar-energy>. [Accessed 28 September 2018].
- [3] A. Baker, 13 July 2013. [Online]. Available:<https://www.solarpowerauthority.com/a-history-of-solar-cells/>. [Accessed 28September 2018].
- [4] S. Wahid, 25 February 2015. [Online]. Available:<https://www.greentechlead.com/solar/tsec-dupont-to-showcase-v-series-solar-panels-at-tokyo-expo-21927>. [Accessed 26 September 2018].
- [5] J Pradeep, "Development of Dual-Axis Solar Tracking using Arduino with LabVIEW," International Journal of Engineering Trends and Technology (IJETT), vol.17, p. 321, 2014.
- [6] G. Kamal, "Final report on dual-axis solar tracking system", Academia, Jul. 2019
- [7] K. Tarlochan, "Arduino based active dual solar tracker", IEEE Conf.,2016
- [8] Solar Tracking Hardware and Software by Gerro J Prinsloo
- [9] Design and Implementation of a Sun Tracker with a Dual-Axis Single Motor "Jing-Min Wang and Chia-Liang Lu"
- [10] Sensors and Transducers...Second Edition..."D.Patranabis"
- [11] Atmel ATmega48A/PA/88A/PA/168A/PA/328/P-datasheet [5] Utilisation of Electrical Power. Author, Er. R. K. Rajput.
- [12] Arduino Programming Book. Author, Brian W. Evan

## Appendix:

```
// Define the LDR and motor driver pin connections
const int LDR1_PIN = A0;
const int LDR2_PIN = A1;
const int LDR3_PIN = A2;
const int LDR4_PIN = A4;

const int MOTOR_PIN1 = 2; // Motor direction pin 1
const int MOTOR_PIN2 = 3; // Motor direction pin 2
const int MOTOR2_PIN1 = 4; // Motor2 direction pin 1
const int MOTOR2_PIN2 = 5; // Motor2 direction pin 2

void setup() {
  // Set the motor driver pins as outputs
  pinMode(MOTOR_PIN1, OUTPUT);
  pinMode(MOTOR_PIN2, OUTPUT);
  pinMode(MOTOR2_PIN1, OUTPUT);
  pinMode(MOTOR2_PIN2, OUTPUT);

  // Start the serial communication
  Serial.begin(9600);
}

void loop() {
  // Read the analog values from LDR1, LDR2, LDR3, and LDR4
```

```

int ldr1Value = analogRead(LDR1_PIN);
int ldr2Value = analogRead(LDR2_PIN);
int ldr3Value = analogRead(LDR3_PIN);
int ldr4Value = analogRead(LDR4_PIN);

// Calculate the absolute differences between LDR1/LDR2 and LDR3/LDR4
int difference1 = abs(ldr1Value - ldr2Value);
int difference3 = abs(ldr3Value - ldr4Value);

// Check if the absolute difference between LDR1 and LDR2 is greater than 10
if (difference1 > 10) {
    // Check if LDR1 is greater than LDR2
    if (ldr1Value > ldr2Value) {
        // Move the motor towards LDR2
        digitalWrite(MOTOR_PIN1, HIGH);
        digitalWrite(MOTOR_PIN2, LOW);
    } else if (ldr2Value > ldr1Value) {
        // Move the motor towards LDR1
        digitalWrite(MOTOR_PIN1, LOW);
        digitalWrite(MOTOR_PIN2, HIGH);
    }
} else {
    // Difference is not greater than 10, stop the motor
    digitalWrite(MOTOR_PIN1, LOW);
}

```

```

digitalWrite(MOTOR_PIN2, LOW);
}

// Check if the absolute difference between LDR3 and LDR4 is greater than 10
if (difference3 > 10) {
    // Check if LDR3 is greater than LDR4
    if (ldr3Value > ldr4Value) {
        // Move MOTOR2 towards LDR3
        digitalWrite(MOTOR2_PIN1, HIGH);
        digitalWrite(MOTOR2_PIN2, LOW);
    } else if (ldr4Value > ldr3Value) {
        // Move MOTOR2 towards LDR4
        digitalWrite(MOTOR2_PIN1, LOW);
        digitalWrite(MOTOR2_PIN2, HIGH);
    }
} else {
    // Difference is not greater than 10, stop MOTOR2
    digitalWrite(MOTOR2_PIN1, LOW);
    digitalWrite(MOTOR2_PIN2, LOW);
}

// Print the LDR values and differences for debugging
Serial.print("LDR1: ");
Serial.println(ldr1Value);

```

```

Serial.print(", LDR2: ");
Serial.println(ldr2Value);
//Serial.print(", LDR3: ");
//Serial.print(ldr3Value);
//Serial.print(", LDR4: ");
//Serial.print(ldr4Value);
Serial.print(", Difference1: ");
Serial.print(difference1);
//Serial.print(", Difference3: ");
//Serial.println(difference3);
delay(2000);
}

```

Code 2:

```

int LDR1_PIN = A0;    // Analog pin connected to LDR1 (east)
int LDR2_PIN = A5;    // Analog pin connected to LDR2 (west)
int POT_PIN = A3;     // Potentiometer analog pin

int RPWM_Output = 5;  // Arduino PWM output pin 5; connect to IBT-2 pin 1
                      // (RPWM)
int LPWM_Output = 6;  // Arduino PWM output pin 6; connect to IBT-2 pin 2
                      // (LPWM)

int motorSpeed = 0;   // Motor speed (controlled by the potentiometer)
int tolerance = 50;   // Adjust the tolerance value as needed

```

```
void setup() {  
  pinMode(LDR1_PIN, INPUT);  
  pinMode(LDR2_PIN, INPUT);  
  pinMode(RPWM_Output, OUTPUT);  
  pinMode(LPWM_Output, OUTPUT);  
  
  Serial.begin(9600);  
}  
  
void loop() {  
  int LDR1 = analogRead(LDR1_PIN);  
  int LDR2 = analogRead(LDR2_PIN);  
  
  motorSpeed = map(analogRead(POT_PIN), 0, 1023, 0, 255);  
  
  Serial.print("LDR1: ");  
  Serial.print(LDR1);  
  Serial.print(" | LDR2: ");  
  Serial.println(LDR2);  
  
  if (abs(LDR1 - LDR2) <= tolerance) {  
    // Stop motor  
    analogWrite(RPWM_Output, 0);  
    analogWrite(LPWM_Output, 0);  
  }  
}
```

```
}  
  
else if (LDR2 < LDR1) {  
  // Move towards LDR2 (west)  
  analogWrite(RPWM_Output, 0);  
  analogWrite(LPWM_Output, motorSpeed);  
} else if (LDR1 < LDR2) {  
  // Move towards LDR1 (east)  
  analogWrite(LPWM_Output, 0);  
  analogWrite(RPWM_Output, motorSpeed);  
}  
  
delay(2000); // Adjust delay as needed  
}
```