

GAIT RECOGNITION PROGRESS IN RECOGNIZING IMAGE CHARACTERISTICS

ASADULLAH KHAN¹, YASER DAANIAL KHAN¹, FAROOQ AHMAD², DAOJING HE³ AND
MUDASSER NASEER²

¹Department of Computer Science, University of Mangement Science, Lahore, Pakistan

²Department of Computer Science, COMSATS Institute of Information Technology, Lahore, Pakistan

³School of Computer Science and Software Engineering, East China Normal University, Shanghai, China

Email: yaser.khan@umt.edu.pk, farooqahmad@ciitlahore.edu.pk, djhe@sei.ecnu.edu.cn,
mnaseer@ciitlahore.edu.pk

Revised December 2015

ABSTRACT. We present a humans credentials system centered on ambulation characteristics. This problem is as eminent as acoustic gait recognition. The objective of the scheme is to explore sounds radiated by walking persons (largely the musical note sounds) and identifies those folks. A cyclic model topology is engaged to denote individual gait cycles. This topology permits modeling and detecting individual steps, leading to very favorable identification rates.

1. **Introduction.** Gait recognition is an up-to-date practice that detects biometric activities of human appearance. At a very low-lying resolution, consumer of graphics could examine gait symbols for immutable event that need in counter compelling, protection, sports and health-related type of inquiry and different methods that could divide human rotation cycle in every phase.

Identification has important theoretical and practical value. Approximation of gait mostly relies upon the observational understandings by which they differ between clinicians and researchers. For instance, the techniques of analysis and monitoring of gait are extensively advanced and proved.

Systems could capture gesture in 3D high speed, location recorded positions of radiating parts of human where they are attached. A person can be recognized by login, through development of auto detection pin allocation without any password input command. Records are saved in database through characteristic functions (e.g. Age, Iris, Face, Retina, Fingerprint, Hand geometry also behavioral functions) and can then be identified.

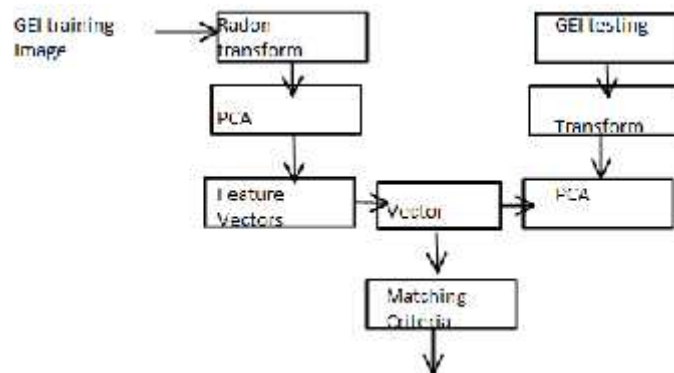

Fig 1. Biological methodology for gait animal locomotion

For understanding species biological methodology of each bit as motive power we attain information on gait animal locomotion and this identifies the dynamics of gait patterns, or many factors effected, comprising environmental factors and physical characteristic quality, walking speed, carrying condition, elapsed time, etc. without assuming the analysis of spatial-temporal motion and structures (see Fig1). The major constituents working, principal component analysis (PCA) and linear discriminant analysis (LDA) also classify the algorithms that Support Vector Machines (SVM). An SVM cause an issue that is known as the “small sample-size (SSS) problem efficient tensor to vector projection algorithm recognize for man gait feature recognition.

2. Basic Idea of HPM. Unique recognition through gait by new properties of human walking representation gait patio-temporal called Gait Energy Image (GEI) is applied to describe in and Calibrate patterns to address technical problem is definition of training, so methodology could suggest in a unique way for human recognition that combine features perfect synthetic templates around geometric gait action. Calculate real templates directly training sequences outline patron. Distortion imitation pattern shamming sequences shadow that we make from training. The best learning for identification geometric create synthetic and actual sampling could be mapped on GEI. Then it cooled compression between GEI Database Methodology and USF then pass an ID for Human Database. Finally that analysis of Experimental results proposed GEI technique is absolutely perfect effectual and is the best gait demonstration of one’s awareness and the methodology recommended conquer highly reasonable operation with respect to print the gait recognition methodologies.

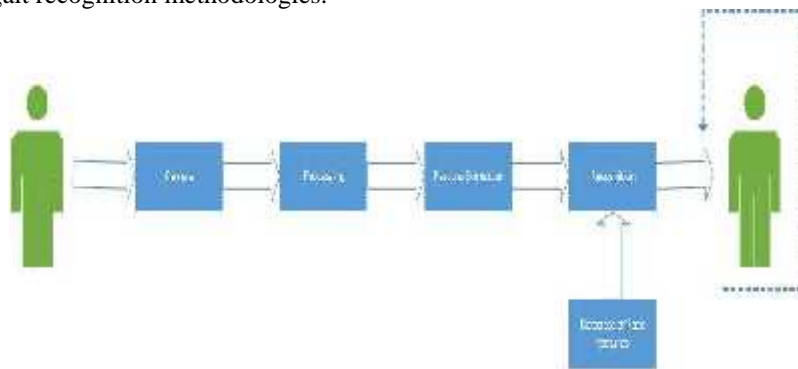

Fig 2. Basic idea of HPM

We explained the illustration (see Fig 2) of gait existence for the intent of individual identification and categorization. This gait representation is based on simple features such as moments extracted from orthogonal view video silhouettes of human walking motion. Despite its simplicity, the resulting feature vector contains sufficient information to execute well on human preference and gender classification tasks. We explore the recognition behavior of two different methods to combine features over time under different recognition tasks. We attest the accuracy of recognition using gait video sequences collected over different days and fourth dimensions and under varying lighting atmospheres. In essence, we have proven results in gender classification based our gait appearance features using a support-vector machine. Human proof of identity at a distance has lately gained growing interest for computer vision investigators. Gait recognition aims basically to sing over this trouble by identifying people based on the way they learn the soft current of air.

In the paper a simple but efficient gait recognition algorithm using spatial-temporal silhouette analysis is run [1]. For each image sequence a background subtraction algorithm and a simple correspondence procedure are first used to segment and pass over the moving silhouettes of a walking frame and then for a second time, space alteration founded on principal component analysis (PCA). Gait is cast off in time-varying distance indicators resulting from the order of silhouette imageries of input feature space to decrease the dimensionality. For recognition managed form of classification methods are finally implemented in the lower-dimensional Eigen space. This method indirectly seizes the structural and intermediate looks of gait. Widespread experimental outcomes on outside image orders, display that the offered algorithm has an expectant recognition presentation with a comparatively low computational price. In the paper [2] dimensionality feature space for samples and under sample problem (USP) that conventional ways lags as compared representations. Some Face matching pattern in 2-D LDA (2DLDA) is actually working on general tensor discriminant analysis (GTDA). Which can overcomes the present processing works due to its compact subsequent classification in USP over LDA. Secondly, it restores the sharp statistics in training tensors that convergence upon discontinuous projections facilitates a firm recognition rate thus optimizes. Using

Gabor-function-based image representations: sum of Gabor filter directions responses, then sum scales overcome by Gabor filter after SD could be calculated by Gabor filter that over scales and instructions. These propose method lies as Human ID Database generate nine state-of-the-art classifications could be recognition gait. In the report [3] use framework that take to attempt overcome problem with an analysis Large gait database that evaluation metric sequence manner. Gait data capture 11 perspectives form. Were some variations are angled, clothes also environments are individual change database are designed in the framework. Some metrics could be analysis, gait recognition with algorithms technique use. In this research body recovers static and stride parameters when they walk away. By using methodologies are extracted to identify properties individual and by their behavior could applicable when if person performing only down specific activity.so we evaluate our boundaries, of database reported correctly. That predicts vector feature identity population by using feature vector. Analysis stride parameters of a body recovered in different angle with time limitation on a database result of walking frontal-parallel position are indoors or out. That could analysis the motion-capture, record to discover when any confusion, visual dimension error physical Generate. He purpose recognized human at a distance by using Vision-based.

That approach is based on framework can track by joint-angle trajectories walker recover at lower branches are dynamic gait (see Fig3). Cues obtained between stable and dynamic walking videos could be classified. At every level different stages could be improve recognition. He suggested algorithm could be feasibility that could arrange data in. In paper [4] author proposed that best gait representation easily build or matching compression with time ideal frame Present a rich gait recognition and one cycle of each silhouette frames average distance between these silhouette representations. Representation can improve by the number of cycle add between each cycle time of the frame so power of image could be enhanced that generate no of points generate on the database so the gait baseline algorithm could be use of comparable standard in gait recognition.

Dynamic representations need for accurate pattern to get recognized. Galary (GAR) , Prob A (GAL) , Prob B (GBR) , Prob C (GBL) Prob D (CAR) , Prob E (CBR) , Prob F (CAL) , Prob G (CBL)

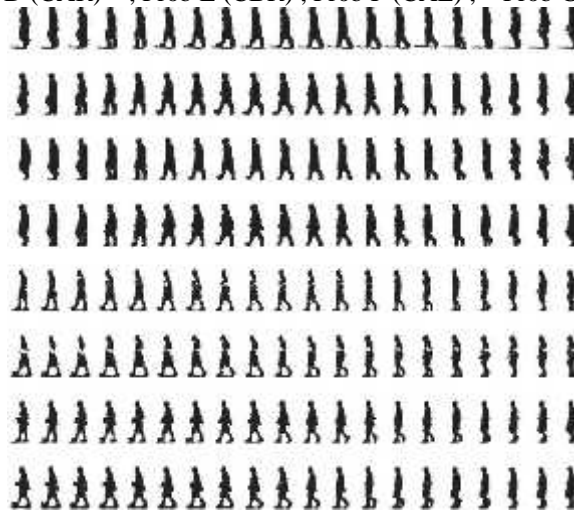

Fig 3. Dynamic representations of joint-angle trajectory walk

In paper [5] author study the algorithm for tensor to vector projection to recognition. It represents (see Fig4) the features of human gait. Multidimensional Technology adopted. Variation in that data well captured so reparability Image class avoid the potential over fitting that evaluate the vector projection algorithm make effectiveness discriminative and sparse tensor.

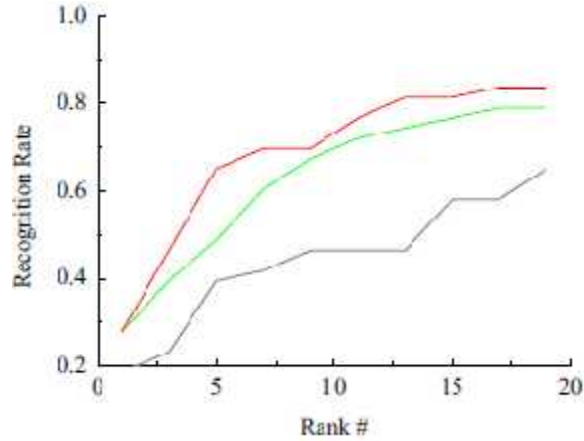

Fig 4. Tensor to vector projection results

In paper [6] author studied pattern analysis algorithm using statistics (see Table1). By involved background image Secular change sequence vector configurations added or subtraction procedure is utilized to extract moving silhouettes, then detected by coordinating frame analyzed shape analysis the structural characteristics depend on the distance between image compressions body biometric shape cues and different viewing angles outdoor environment. In the paper [7] author identify human by their walking sounds. The major problem called acoustic gait recognition. The goal of the system is to analyses sounds emitted by walking persons (mostly the step sounds) and identifies those persons. A cyclic model topology is employed to represent individual.

3 Technical Frameworks. Walk manner [8] of foot moving on related to the behavioral characteristics of biometric recognition (see Fig 5). Biometric technology Gait recognition is one kind of monitor people. Technique to interaction feature of this image frame is extracted length of the cycle and mass of step size and cycle length using Bonn and swim technique is used

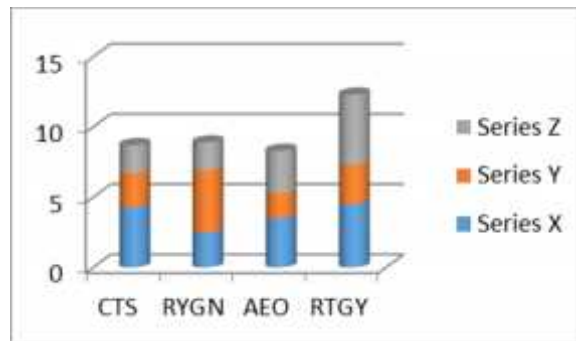

Fig 5. Results of behavioral characteristics of biometric recognition

Support vector machine (svm) by Gaussian kernel is defined by:

$$k(x_i, y_j) = \exp\left(-\frac{\|x_i - y_j\|^2}{2\sigma^2}\right)$$

Gait cycles. This topology allows modeling and detecting individual steps, leading to very promising identification rates. Partition of the TUM GAID database Development Test

N1 – N4 Enrollment Enrollment

N5 – N6 Identification Identification

Svm first maps introducing Lagrangian multipliers and solved any problem by quadratic programming (qp) . Original space that is called kernels. Radial basis function (rbf). [9] various gait parameters. Divided into three

categories 1 image processing based on measurement IP so image mentsa of the image reproduced with.

Present: depth measurement, also called range imaging map of distances between CMS (complementary metal semiconductor) and CCD (charge coupled device) coupled changes in time-of-flight systems (tof)

$$g_i = \frac{\lambda_m}{z} \cdot \frac{\Phi_i}{2\pi}$$

λ_m Wavelength is modulation signal. Unambiguous poison of Camera periodicity of the modulation signal, range is

$$d_n = c/2 \cdot f_{mod}$$

Calculated exclusively [10] .Phase Shifting between reference signal received by camera range depends on the modulation frequency wavelength of the emitted signal received.

Φ_i Distance property defines. Derawi et al. joints different segments of body could be extracting human gait

$$\phi_i = \tanh^{-1} \left[\frac{s_i(\tau_0) - s_j(\tau_2)}{s_i(\tau_1) - s_j(\tau_3)} \right]$$

$$a_j = \frac{\sqrt{[s_i(\tau_0) - s_j(\tau_2)] - [s_i(\tau_1) - s_j(\tau_3)]}}{\lambda a}$$

$$b_i = \frac{\sum_{j=0}^3 (s_i(\tau_j))}{4}$$

Light patron projection structured are grid, coded light, beam, 2D, angular velocity to be calculated Kinect sensor using a merciless system and infrared thermography (irt) surface temperatures based on process visual images (see Fig 6). Human intensity possible Absorptivity is (0.98 ± 0.01) at reflectivity (0.02) in emissivity 0.98 ± 0.01 . And transmissivity (0.000) are patterns recognize human gait that analyses 78%–91% for probability of correct result

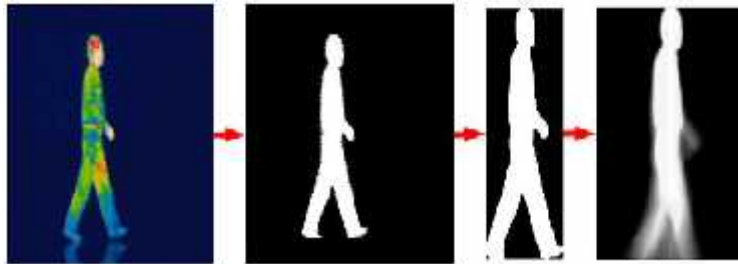

Fig 6. visual images

Moments measurement components are measure its axis for anti-forces using body . It includes sensor Wearable accelerometers, extensometers, gyroscopes, goniometers, Inclometers, electromyography, active markers, etc. Measure return a current or voltage proportional to the pressure measured. That Inertial sensors are measure and tell the object's inertial measurement units (Imus), velocity, gravitational forces, acceleration, orientation, and comparison between general disadvantages and advantages by use this systems effect factors are power consumption, parameter measurement range, and time limitations.

$$K(X_i, X_j) = \exp\left(-\frac{\|X_i - X_j\|^2}{2\sigma^2}\right)$$

In paper [11], author used gait energy image (Ge) and apply principal component analysis (pca) without any radon transform (Rt) (see Fig 7).The moving cmu database can be purposes. Low error rates (ear) of 94.23%,

82.28%, 90.38% and for pca only and 82.70% ,96.15% and 92.30% and pca with slow walk (see Fig 8).

$$u[m] = \frac{1}{N} \sum_{n=1}^N X[m, n]$$

$$B = X - u$$

$$C = E[B \otimes B] = E[BB^*] = \frac{1}{N} \sum BB^*$$

Technique to analysis and root Principal component are:

$$F(\rho, \theta) = \int_{-\infty}^{\infty} \int_{-\infty}^{\infty} (x, y) \delta(\rho - x \cos \theta - y \sin \theta) dx dy$$

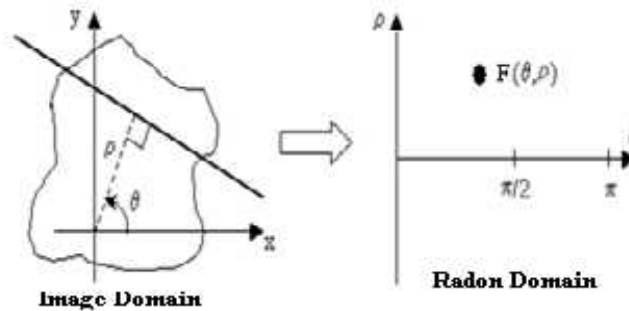

Fig 7. From image domain to radon domain

Total number of image or reduces its dimensional in a tuning value; $j, k = 1, 2, 3, \dots, n$ [12].

$$T = \frac{[\max \langle \|\Omega_j - \Omega_k\| \rangle]}{T_{cpara}}$$

Techniques was proposed based on PCA with rate and only poke a age template gait sequences. Using Real-time gait cycle could be recognition as accelerometer and disease or K-accelerometer ,Parkinson's and wearable accelerometer are impact on system Using tri-axial accelerometers, the wearable motion analysis to measure trunk walking accelerations cycle could regularity.

$$a_m = \sum_{i=1}^{N-|m|} X_i X_{i+m}$$

$$a_m^{unbiased} = \frac{1}{N - |m|} \sum_{i=1}^{N-|m|} X_i X_{i+m}$$

$$2N-1 \quad A = [a_{-m, a-m+1}, a_0, a_1, a_{m-1}, a_m]$$

$$Dis(p_i, q_i) = |K(q_i) - K(p_i)|$$

$$S = \{(p_i, q_i) | q_i \in H_{min}^{mix}, p_i \in H_{max}^{mix}, \delta < Dis(p_i, q_i) < \varepsilon\}$$

$$P_k^\theta = S_{\beta} \cdot R_{\beta \rightarrow \theta}, k = 1 \dots N, \theta = 0^\circ, \Delta\theta, 2\Delta\theta, \dots, 90^\circ$$

Table 1: Comparative results of the proposed methods and two previous methods with parameter p set to 2.5

	Normal Walk (%)		Slow Walk (%)		Fast Walk (%)		Carrying Bags (%)		Carrying Ball (%)		Overall (%)	
	Rank 1	Rank 5	Rank 1	Rank 5	Rank 1	Rank 5	Rank 1	Rank 5	Rank 1	Rank 5	Rank 1	Rank 5
Frontal GEI [6]	87.0	95.7	76.1	93.5	67.4	87.0	8.7	28.3	32.6	63.0	54.4	73.5
Frontal-GENI [6]	87.0	95.7	69.6	84.8	60.9	82.6	13.0	30.4	32.6	58.7	52.6	70.4
GDE	91.3	95.7	76.1	93.5	69.6	87.0	8.7	30.4	34.8	65.2	56.1	74.3
PGDE	82.6	93.5	56.5	84.8	58.7	84.8	30.4	54.3	58.7	84.8	57.4	80.4
DGDE	93.5	95.7	78.3	93.5	76.1	89.1	8.7	34.8	32.6	69.6	57.8	76.5
PDGDE	87.0	95.7	71.7	93.5	73.9	89.1	34.4	84.8	78.3	91.3	73.0	90.9
FGDEs	93.5	97.8	80.4	91.3	89.1	95.7	67.4	84.8	76.1	87.0	81.3	91.3

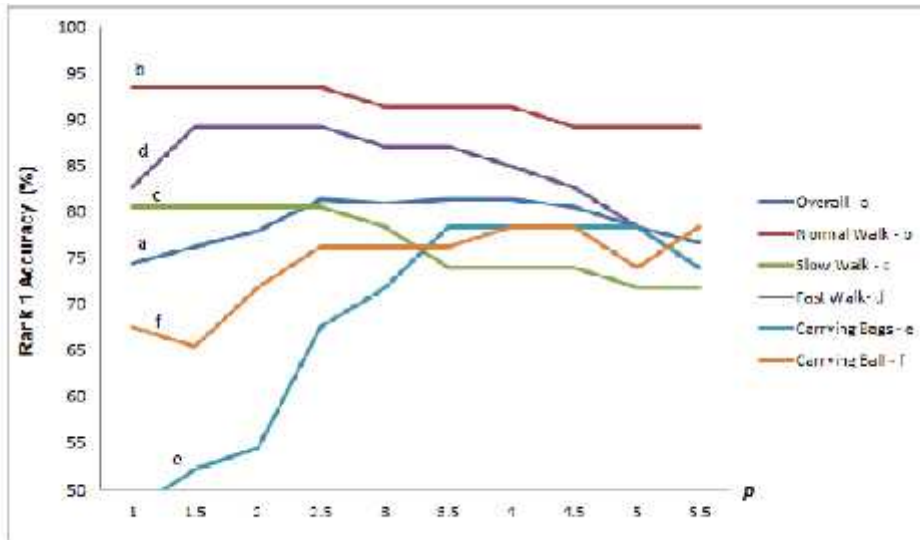

Fig. 8. The impact of the power factor p on the overall and walking covariates for Rank 1 accuracy

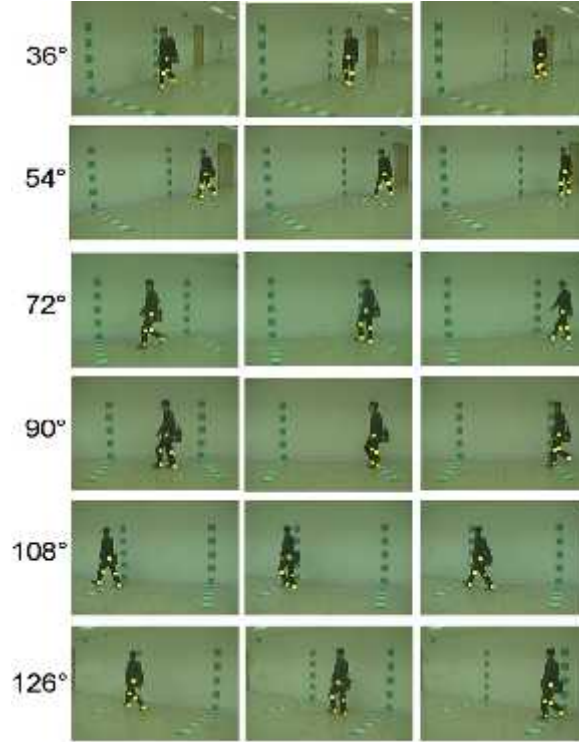

Fig 9. Multi view images

Model (vtm) having independent matrix subject Point Multiple-view images (see Fig 9). These classifying matrix d between Lenin portion surface position of human body image are division into max match point are calculated Technology Microelectronic mechanical systems are use Personal digital assistant (PDAs) of location based services (lbs.). That Generate sensor Grade memes sensors, inertial force and a noise term to accelerometer. Remove noise data in motion Extracting or predict meaningful parameter.

4. Comparative study. Last and the important comparison based on the practical implementation of the technique used. In [2] they used mobile

$$\mathbf{S}[\mathbf{n}] = \begin{bmatrix} \mathbf{S}^a[\mathbf{n}] \\ \mathbf{S}^\omega[\mathbf{n}] \end{bmatrix} = \begin{bmatrix} \mathbf{a}[\mathbf{n}] \\ \boldsymbol{\omega}[\mathbf{n}] \end{bmatrix} + \begin{bmatrix} \boldsymbol{\eta}^a[\mathbf{n}] \\ \boldsymbol{\eta}^\omega[\mathbf{n}] \end{bmatrix}$$

[14] Wearable sensors clinical application use same as all above could discuss

$$\delta_{(\tau,\psi)}^f(t,p) = \cos[\omega_p \cdot (p - \psi) + \omega_t \cdot (t - \tau)] \cdot \exp\left(\frac{(p-\psi)^2}{2\sigma_p^2} - \frac{(t-\tau)^2}{2\sigma_t^2}\right),$$

$$\delta_{(\tau,\psi)}^b(t,p) = \cos[\omega_p \cdot (p - \psi) - \omega_t \cdot (t - \tau)] \cdot \exp\left(\frac{(p-\psi)^2}{2\sigma_p^2} - \frac{(t-\tau)^2}{2\sigma_t^2}\right)$$

[15] Action re Cognitions; biological motion; model; motion; motion energy of parts are division into motion-selective neurons body parts.

$$R_\psi(t) = \sum_{i=1}^N \exp\left(\frac{|(X_i(t), Y_i(t)) - (X_{i,\psi}, Y_{i,\psi})|^2}{2 \cdot \sigma}\right),$$

technology in analysis as this is cheap and implemented by the author and also provide ease of use. In [3] we need special type of cameras and if human body temperature increased or decreased due to any reason it will alter the results, so this is not practically applicable.

Cost effect a lot of the time we chose a system to use or deployed. Cost comparison shows that at the highest level is because they use infrared cameras which are high cost and their maintenance is also high (see Table 3 and Fig 10).

Table 2: Performance comparison of LTSM, HMM and DT

Angle	PHMM	Frieze feature			Wavelet feature		
		DT	HMM	LTSM	DT	HMM	LTSM
0	94.4	59.7	95.2	97.6	62.9	100	100
18	86.3	54.8	84.7	91.9	56.5	100	96.8
36	85.9	49.2	84.7	86.3	54.8	100	92.7
54	88.7	54.8	93.5	94.4	57.8	93.4	96.8
72	89.5	54.8	90.3	99.2	58.9	91.1	97.6
90	90.3	58.1	91.1	95.2	61.3	90.3	95.2
108	85.9	49.2	86.3	91.9	57.8	90.3	96.8
126	85.5	54.8	84.7	84.7	56.5	86.3	91.9
144	89.9	53.2	85.5	93.5	57.2	91.9	95.2
162	90.7	57.8	88.7	85.5	59.7	91.9	89.5
180	93.4	58.1	95.2	99.2	61.3	97.6	100
Avg.	89.2	55.0	89.1	92.7	58.6	93.9	95.7

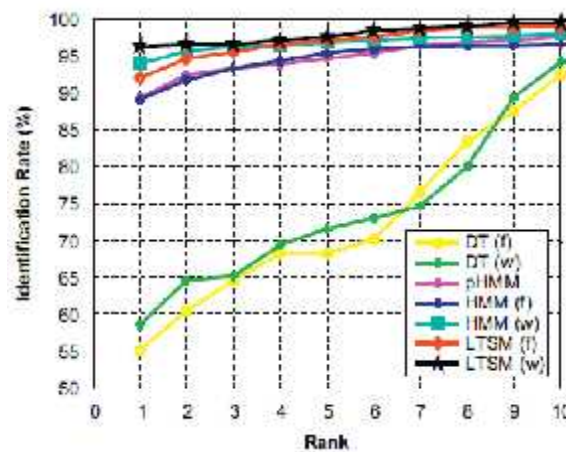

Fig. 10 The CMS curves of DT, HMM, pHMM and LTSM using frieze feature and wavelet feature.

Cost is low because they only make comparison between the predefined and extracted images. At next Manpower requirement affects the overall cost and efficiency of the system. Comparison of manpower required in research papers shows in that paper.

Conclusion. Analysis of gait pattern can be modified in many factors transient and permanent. Impressive performance of XGP could be explained by the fact that so far we tried to evolve very close signatures of three different gaits of a single person by computational effort of XGP. Half gait cycle is modeled by one pass through a cyclic HMM. This covers the sound of one step and adjacent sounds, which are mainly produced by moving arms and legs. The most renowned databases are SOTON, UCSD, USF, CASIA gait database and CMU Mobo gait database. We used different technology i.e. SVM, DWM, DCV, PCA, Gabor filter, and HMM. Some know

techniques are time consuming having high computational work and other calculations are slow while some are also domain specific which require domain expert to apply them for accuracy and efficiency analysis.

REFERENCES

- [1]. Chen, C. H., Pau, L. F., & Wang, P. S. P. (Eds.). (2010). *Handbook of pattern recognition and computer vision* (Vol. 27). Imperial College Press.
- [2]. Tang, J., Luo, J., Tjahjadi, T., & Gao, Y. (2014). 2.5 D multi-view gait recognition based on point cloud registration. *Sensors*, 14(4), 6124-6143.
- [3]. Susi, M., Renaudin, V., & Lachapelle, G. (2013). Motion mode recognition and step detection algorithms for mobile phone users. *Sensors*, 13(2), 1539-1562.
- [4]. Muro-de-la-Herran, A., Garcia-Zapirain, B., & Mendez-Zorrilla, A. (2014). Gait analysis methods: An overview of wearable and non-wearable systems, highlighting clinical applications. *Sensors*, 14(2), 3362-3394.
- [5]. Theusner, S., de Lussanet, M., & Lappe, M. (2014). Action recognition by motion detection in posture space. *The Journal of Neuroscience*, 34(3), 909-921.
- [6]. Yang, C. C., Hsu, Y. L., Shih, K. S., & Lu, J. M. (2011). Real-time gait cycle parameter recognition using a wearable accelerometry system. *Sensors*, 11(8), 7314-7326.
- [7]. Ali, H., Dargham, J., Ali, C., & Mounq, E. G. (2011). Gait recognition using gait energy image. *International Journal of Signal Processing, Image Processing and Pattern Recognition*, 4(3), 141-152.
- [8]. Muro-de-la-Herran, A., Garcia-Zapirain, B., & Mendez-Zorrilla, A. (2014). Gait analysis methods: An overview of wearable and non-wearable systems, highlighting clinical applications. *Sensors*, 14(2), 3362-3394.
- [9]. Joshi, A., Bhushan, S., & Kaur, J. (2014). Gait Recognition of human using SVM and BPNN classifiers. *International Journal of Computer Science and Mobile Computing*, 3(1), 281-290.
- [10]. Geiger, J. T., Kneißl, M., Schuller, B. W., & Rigoll, G. (2014, November). Acoustic gait-based person identification using hidden Markov models. In *Proceedings of the 2014 Workshop on Mapping Personality Traits Challenge and Workshop* (pp. 25-30). ACM.
- [11]. Afendi, T., Kurugollu, F., Crookes, D., & Bouridane, A. (2014, September). A frontal view gait recognition based on 3D imaging using a time of flight camera. In *Signal Processing Conference (EUSIPCO), 2014 Proceedings of the 22nd European* (pp. 2435-2439). IEEE.
- [12]. Bouchrika, I., Carter, J. N., & Nixon, M. S. (2016). Towards automated visual surveillance using gait for identity recognition and tracking across multiple non-intersecting cameras. *Multimedia Tools and Applications*, 75(2), 1201-1221.