

FINAL YEAR PROJECT REPORT

Solar Powered Car



Project Advisor

Mr. Salman Khaliq

Co-Advisor

Mr. Muhammad Salik

Submitted by

Raza Ahmed Aejaz - 081220198

UzairKhawar - 081220205

Durraze Khan - 081220226

Department of Electrical Engineering
School of Science and Technology
University of Management and Technology

Solar Powered Car

Project Report submitted to the
Department of Electrical Engineering, University of Management and
Technology
in partial fulfillment of the requirements for the degree of
Bachelor of Science
in
Electrical Engineering

Raza Ahmed Aejaz - 081220198

Durraze Khan - 081220226

UzairKhawar - 081220205

August 30, 2012

Advisor Approval

This report describes the final-year-project, “Solar Powered Car”, SOLAR CAR, advised by me. It is submitted to the Department of Electrical Engineering, UMT, Lahore, with my approval.

Salman Khaliq
Advisor

Muhammad Salik
Co-Advisor

August 30, 2012

Table of Contents

Advisor Approval.....	iv
Table of Contents	v
List of Figures.....	ix
Acknowledgement	x
Abstract.....	xi
Chapter 0: Introduction	1
0.1 Solar Power	1
0.2 Solar Panels.....	2
Chapter 1: Architecture	6
1.1 Hardware Block Diagram.....	6
1.1.1 Solar Car	6
1.1.2 Remote Control.....	6
Chapter 2: Design	7
2.1 Power.....	7
2.1.1 Phase 1	7
2.1.2 Phase 2	9
2.1.3 Phase 3.....	9
2.2 Wireless Control.....	10
2.2.1 Transmitter Control.....	11
2.2.2 Receiver Control	12
2.3 Voltmeter.....	13
2.4 Motor Control Circuit.....	14
2.4.1 Version 1	14
2.4.2 Version 2.....	16
.....	17
.....	17

2.5	Battery Level Indicator.....	18
2.6	Microcontroller.....	19
2.6.1	Version 1.....	19
2.6.2	Version 2: Overvoltage Protection.....	20
Chapter 3: Testing		21
3.1	Voltage Regulator Circuits.....	21
3.2	Wireless Control.....	21
3.3	Motor Control Circuits.....	22
3.4	PCB and Vero-Boards.....	22
3.5	Voltmeter.....	22
Chapter 4: Simulations.....		23
4.1	Power.....	23
4.1.1	Phase 1.....	23
4.1.2	Phase 2.....	24
4.1.3	Phase 3.....	25
	25
4.2	Motor Control Circuit.....	26
4.2.1	Version 1.....	26
4.2.2	Version 2.....	27
	27
4.3	Remote Control.....	28
4.3.1	Transmitter Control.....	28
4.3.2	Receiver Control.....	29
4.4	Voltmeter.....	30
4.4.1	Digital Voltmeter.....	30
4.4.2	Battery Level Indicator	31
Chapter 5: User Guide.....		32

5.1	Safety Precautions	32
5.2	Parts of SOLAR CAR	32
5.3	Starting Up SOLAR CAR.....	33
5.4	Operating SOLAR CAR.....	33
Bill of Materials.....		34
	Solar Car.....	34
	Remote Control	36
ACRONYMS.....		37
References.....		38
Index.....		40

List of Figures

Figure 1: Hardware Block Diagram of Solar Car	Error! Bookmark not defined.
Figure 2: Hardware Block Diagram of Remote Control.....	6
Figure 3: Software Block Diagram of Solar Car	Error! Bookmark not defined.
Figure 4: Remote Control Block Diagram.....	Error! Bookmark not defined.
Figure 5: Voltage Regulator [1].....	7
Figure 6: Variable Voltage Regulator using LM317 IC [2]	8
Figure 7: Voltage Regulator using LM7805 IC [3]	9
Figure 8: Block diagram wireless control [4]	10
Figure 9: Wireless Transmitter Circuit [5].....	11
Figure 10: Wireless Receiver Circuit [5].....	12
Figure 11: Voltmeter in stand-alone mode [6].....	Error! Bookmark not defined.
Figure 12: Voltage Calculation.....	Error! Bookmark not defined.
Figure 13: Voltage Regulator Circuit using LM317 IC.....	23
Figure 14: Voltage Regulator Circuit for 12V to 5V	25
Figure 15: Voltage Regulation Circuit using LM7805 IC	24
Figure 16: Motor Control Circuit Version 1	26
Figure 17: Motor Control Circuit Version 2	27

Acknowledgement

Our first and foremost thanks are to ALLAH for his countless blessings in enabling us to complete this project. Then thanksto our families for providing us thesupportwe needed throughout this period. We would also like to thank thefaculty, colleagues, and FYP (Final Year Project) committee members, lab assistants, our advisor Sir Salman Khaliq, Our Co-Advisor Sir Muhammad Salik, and especially Sir MashoodNasir for their great support through our the Project duration. We would like to thank our Final Year Project director Mr. Rauf Ali for issuing the Solar Panel from the project's lab.

Abstract

The present sources of energy (*Petroleum, Natural gas, and coal*) are limited and facing depletion. Solar energy is one of the most abundant resources available in Pakistan. Our project was to design and implement an instrumentation module for a remote controlled car powered by solar energy. The instrumentation module consists of two main parts, a solar car and a remote control. The remote control controls the left, right, forward, and reverse functions of the solar car. The solar car receives commands from the remote control and functions accordingly. The voltage of the solar car is also measured and displayed on the LCD attached with solar car. Solar car was remotely controlled. Other than that, we learnt the complexities of working with hardware, software, and the issues involving PCB (Printed Circuit Board) design and fabrication, Vero-Board design and testing. All the relative pictures, videos, datasheets, documents, simulations, codes, designs, software, presentations, and helping material is included in our FYP CD. Please consult it for further information on our project.

Chapter 0: Introduction

0.1 Solar Power

Due to depletion of natural resources worldwide research in alternative forms of energy is enhanced. Also in Pakistan the federal government has encouraged alternative forms of transportation due to a limited supply of oil and increasing environmental pollution. Nowadays solar cars are just one of many transportation concepts emerging. Solar cars use solar cell panels instead of gasoline as the fuel. As a result, exhaust fumes and oil consumption are eliminated.

The solar cell panel generates an electrical charge that is stored in a battery and used to provide energy as the vehicle is driven. The lighter the vehicle, the less energy used and the farther the vehicle will travel. In cloudy days, or at night, energy can be drawn from reserve batteries. In the future, charge stations will be located on the road sides for quick battery charging.

A solar car is an electric vehicle powered completely or significantly by direct solar energy. Usually, photovoltaic (PV) cells contained in solar panels convert the sun's energy directly into electric energy. The term "solar car" usually implies that solar energy is used to power all or part of a vehicle's propulsion.



0.2 Solar Panels

A solar panel is a packaged, connected assembly of photovoltaic cells. The solar panel can be used as a component of a larger photovoltaic system to generate and supply electricity in commercial and residential applications. Each panel is rated by its DC output power under standard test conditions, and typically Solar panels used for residential applications ranges from 100 to 450 watts.

0.2.1 Relation between Area and Efficiency:

The efficiency of a panel determines the area of a panel given the same rated output - an 8% efficient 230 watt panel will have twice the area of a 16% efficient 230 watt panel. Because a single solar panel can produce only a limited amount of power, most installations contain multiple panels. A photovoltaic system typically includes an array of solar panels, an inverter, and sometimes a battery and or solar tracker and interconnection wiring.

0.2.2 Construction

Solar panels use light energy (photons) from the sun to generate electricity through the photovoltaic effect. The structural (load carrying) member of a module can either be the top layer or the back layer. The majority of modules use wafer-based crystalline silicon cells or thin-film cells based on cadmium telluride or silicon. The conducting wires that take the current off the panels may contain silver, copper or other non-magnetic conductive transition metals.

Electrical connections are made in series to achieve a desired output voltage and/or in parallel to provide a desired current capability. Separate diodes may be needed to avoid reverse currents, in case of partial or total shading, and at night.

0.2.3 Different types of Solar Panels

Monocrystalline silicon (mono-silicon or single silicon)

These are the most efficient type of solar panels. In other words, when sunlight hits these cells, more of it turns into electricity than the other types below. As a result of their high silicon content, they're also more expensive, but you need fewer of them. That's why they're ideal for oofs. You can tell if you have a monocrystalline solar panel by its square-ish cells.



Polycrystalline silicon (multicrystalline, multi-silicon, ribbon)

“Poly” panels have lower silicon levels than “mono” panels. In general, that makes them less expensive to produce, but they’re also slightly less efficient. The good news is that their overall construction design can often make up for the efficiency loss, so they’re also good for roofs. You can tell poly-silicon panels by their groovy mélange of silicon woven through thin rectangular conduit wires.

Thin film (amorphous silicon, cadmium telluride)

Poly” panels have lower silicon levels than “mono” panels. In general, that makes them less expensive to produce, but they’re also slightly less efficient.



0.3 Performance and Lifetime

Electrical characteristics include nominal power (P_{MAX} , measured in W), open circuit voltage (VOC), short circuit current (ISC, measured in amperes), maximum power voltage (VMPP), maximum power current (IMPP), peak power, W_p , and module efficiency (%).

Open circuit voltage or VOC is the maximum voltage that the panel can produce when not connected to an electrical circuit or system. VOC can be measured with a meter directly on an illuminated panel's terminals or on its disconnected cable.

The peak power rating, W_p , is the maximum output according under standard test conditions (not the maximum possible output). Typical panels, which could measure approximately 1x2 meters or 2x4 feet, will be rated from as low as 75 Watts to as high as 350 Watts, depending on their efficiency. At test panels are binned by their test results, and a typical manufacturer might rate their panels in 5 Watt increments, and either rate them at +/- 3%, +/-5%, +3/-0% or +5/-0%.

Solar panels must withstand heat, cold, rain and hail for many years. Many crystalline silicon module manufacturers offer a warranty that guarantees electrical production for 10 years at 90% of rated power output and 25 years at 80%. The output power of many panels slowly degrades at about 0.5%/year.

0.4 Limitations

There are limits to using photovoltaic (PV) cells for vehicles:

Power density

Power from a solar array is limited by the size of the vehicle and area that can be exposed to sunlight. While energy can be accumulated in batteries to lower peak demand on the array and provide operation in sunless conditions, the battery adds weight and cost to the vehicle. The power limit can be mitigated by use of conventional electric cars supplied by solar (or other) power, recharging from the electrical grid.

Cost

While sunlight is free, the creation of PV cells to capture that sunlight is expensive. Costs for solar panels are steadily declining (22% cost reduction per doubling of production volume).

Design Considerations:

Even though sunlight has no lifespan, PV cells do. The lifetime of a solar module is approximately 30 years. Standard photovoltaics often come with a warranty of 90% (from nominal power) after 10 years and 80% after 25 years. Mobile applications are unlikely to require lifetimes as long as building integrated PV and solar parks. Current PV panels are mostly designed for stationary installations. However, to be successful in mobile applications, PV panels need to be designed to withstand vibrations. Also, solar panels, especially those incorporating glass have significant weight. To be useful, the energy harvested by a panel must exceed the added fuel consumption caused by the added weight.

Chapter1:Architecture

1.1 Hardware Block Diagram

1.1.1 Solar Car

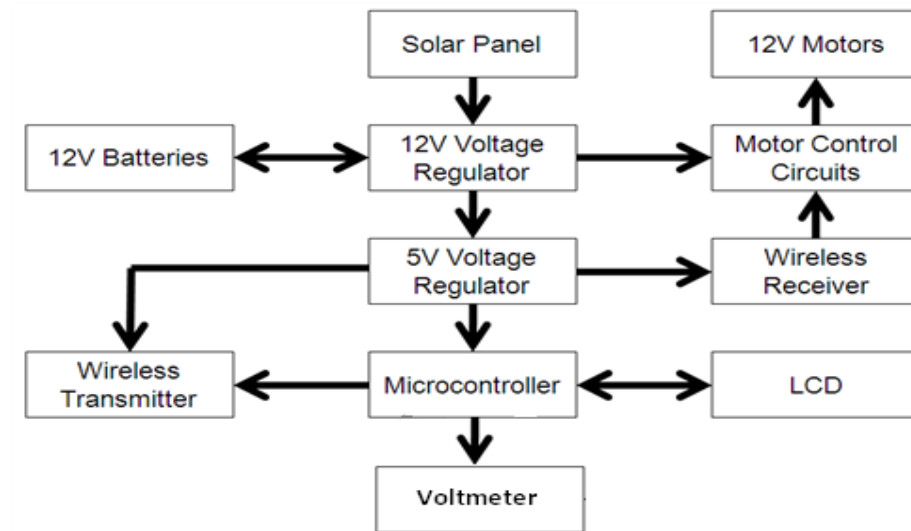

Figure 1: hardware Block Diagram of Solar Car

1.1.2 Remote Control

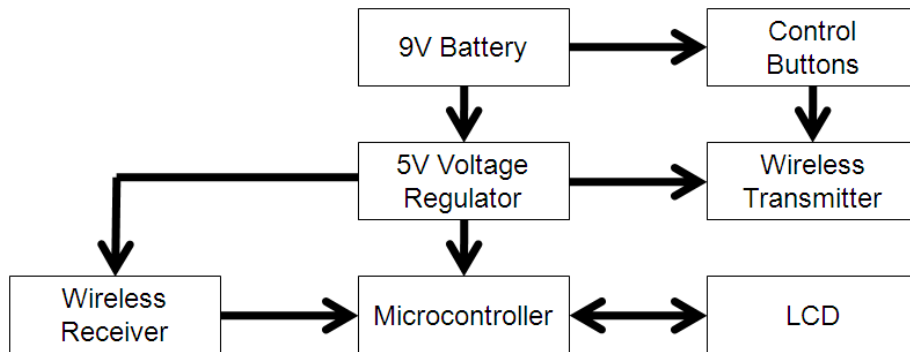

Figure 1: Hardware Block Diagram of Remote Control